



ghostONE

Operating instructions - English

Copyright and trademarks

Copyright 2024 eSystems MTG GmbH

All rights reserved.

Subject to availability and technical modifications.

All hardware and software names used are trade names and/or registered trademarks of the relevant companies.

Issued by: 03/2024

Revision: 3.0

Contents

1 Introduction	6
1.1 Intended use	6
1.2 Documentation concept and target group	6
1.3 Copyright	7
1.4 Legal notices	7
1.5 Means of representation	8
2 Safety	10
2.1 Safety symbols	10
2.2 Intended use	11
2.3 Safety information for operation	11
3 Product overview	13
3.1 Design	13
3.2 Functions	14
3.3 Items supplied	17
3.4 Access data	18
3.5 Wallbox web app	20
4 Front panel	21
4.1 Front panel	21
4.2 Displays and controls	22
5 Assembly and installation	25
5.1 Attaching the lock/lead seal	25
6 Commissioning and configuration	27
6.1 Connecting to the Wallbox using the web app	27
6.2 Configuring wallbox network settings	28
6.2.1 Ethernet	28
6.2.2 WiFi hotspot	29

6.2.3 WiFi client	31
6.2.4 LTE	32
6.3 Authenticating on the Wallbox	33
7 Operation	34
7.1 Login/logout	34
7.2 Information in the overview	35
7.3 Charging a vehicle	36
7.3.1 Starting charging	36
7.3.2 Charging with RFID chip	38
7.3.3 Pausing charging	39
7.3.4 Finishing charging	39
7.3.5 Configuring the PLC connection to the vehicle	40
7.3.6 Charging information and settings	40
7.4 1-/3-phase switching	41
7.5 Enabling / disabling Free-Charging (charging without authentication)	42
7.6 Managing the approved list	42
7.6.1 Adding an RFID chip to the approved list	42
7.6.2 Changing the RFID chip name in the approved list	43
7.6.3 Removing an RFID chip from the approved list	44
7.7 Managing OCPP settings	44
7.7.1 Connecting the Wallbox via OCPP	44
7.8 Managing smart charging / smart home	45
7.8.1 Configuring the Wallbox for a smart home EMS via EEBUS	45
7.9 Configuring general settings	47
7.9.1 Enabling/disabling eco mode	47
7.9.2 Setting the LED brightness	47
7.9.3 Changing password	47
7.9.4 Setting the language	48
7.9.5 Showing system settings	49
7.9.6 Setting units	50
7.9.7 Configuring the socket locking/unlocking	50
7.9.8 Enabling/disabling the earth monitoring system	50

7.9.9 Showing the energy meter status	51
7.10 Restarting the wallbox	52
7.11 Resetting to factory defaults(Factory-Reset)	52
7.12 Updating the software	53
7.12.1 Software update information	53
7.12.2 Manually updating the software	54
7.12.3 Performing an automatic software update	54
7.12.4 Performing a local software update	55
8 Service and cleaning	56
8.1 Performing recurring checks	56
8.2 Wallbox Cleaning	58
9 Troubleshooting	59
9.1 Performing a self-test	59
9.2 Identifying and fixing errors	59
9.2.1 Fixing errors	60
9.2.2 Error codes	61
9.3 Initiating emergency measures	86
10 Shutdown and uninstalling	87
11 Storage	88
12 Disposal	89
13 Technical data	90
14 Technical glossary	95
15 Index	98

1 Introduction

1.1 Intended use

The ghostONE is a Wallbox with network capability. It is used for charging electric vehicles that comply with the generally applicable standards and directives for electric vehicles.

It is suitable for stationary use indoors and outdoors and in private and semi-public spaces for operation within the defined electrical and environmental specifications, see [Technical data](#).

The Wallbox may only be operated in compliance with all national regulations at the place of use.

The Wallbox is available with the following optional functions:

- LTE
- With charging cable or socket
- With MID-compliant energy meter or
- With MID-compliant energy meter and entire device compliant with German calibration law

1.2 Documentation concept and target group

The documentation for the Wallbox includes the following instructions:

Type of instructions	Contents	Target group
Operating instructions	Describes the configuration and operation of the Wallbox using the front panel and the web app, as well as the entire life cycle of the Wallbox.	Users/operators. This excludes children or persons who are unable to adequately assess the hazards involved in using the Wallbox.

Type of instructions	Contents	Target group
Assembly and installation instructions	Describes the mechanical and electrical installation of the Wallbox. Work steps described in these instructions must only be performed by qualified specialist personnel.	Electrical engineers and specialist companies approved by the network operator who are responsible for installation and commissioning of the Wallbox.
Quick start guide	Describes the most frequent application situations after installation.	Users/operators. This excludes children or persons who are unable to adequately assess the hazards involved in using the Wallbox.

Storing the documentation

- The documentation must be securely stored and handed over to the new owner in the event of sale.

1.3 Copyright

© 2024 – These operating instructions contain material owned by eSystems MTG GmbH. All rights reserved.

This document may not be modified, reproduced, processed or transmitted in any form or by any means, in whole or in part, without the prior written permission of eSystems MTG GmbH.

ⓘ Note

The Wallbox software uses open source software components. Details of their names, licencing model, version number and description are also listed in the copyright information in the web app.

1.4 Legal notices

Notes on using the web app

ⓘ Note

Conditions for using the web app and for personal data processing can be found in the web app's terms of use.

Official calibration conformity (only relevant to Germany)

The manufacturer's seal is attached to the meter, which conforms to official calibration requirements, by the manufacturer during production. It ensures that any manipulation to the wiring or the built-in energy meter can be detected. The manufacturer's seal must not be removed or damaged during the service life of the Wallbox.

Damage to the official manufacturer's calibration conformity seal or damage to or removal of the operator's seal results in immediate revocation of the official calibration conformity of the Wallbox, regardless of the intervals for official calibration tests. The operator is authorised to affix a new operator's seal.

If the manufacturer's seal is broken, attaching a new seal without the supervision of the official calibration authority or its representative is prohibited.

- Observe the intervals for official calibration tests on energy meters.

Manufacturer's seal

The attached annex shows examples of intact or damaged manufacturer's seals.

Operator's seal

The operator's seal is attached to the cover with a screw by the installation engineer after installation of the Wallbox is completed, see assembly and installation instructions.

QR code sticker (if included in the scope of delivery)

The installation engineer attaches the QR code sticker to the side of the Wallbox once installation of the Wallbox has been completed, see assembly and installation instructions.

1.5 Means of representation

The following means of representation are used:

Means of representation	Meaning
Bold script within running text	Texts from the web app
<i>Blue italics</i>	Link to a related topic.
▪	Instruction that you have to follow.
1.	Instructions are numbered if a series of multiple steps have to be carried out.

Screenshots

Some of the screenshots are system-specific and therefore may not match the display in your system in every detail. There may also be system-based differences in the menus and their commands.

2 Safety

2.1 Safety symbols

In these instructions, warning notices appear before sequences of actions that involve a risk of injury or damage. The measures described to prevent the hazard must be adhered to.

Layout of warning notices

SIGNAL WORD

Cause of the hazard

Remedy

- Action 1
- Action 2

- Warning sign draws attention to the hazard.
- Signal word indicates the severity of the hazard.
- Cause of the hazard specifies the nature and source of the hazard.
- Remedy specifies how the hazard can be averted.

Meaning of symbols

DANGER

Hazardous situation in which death or serious injury will occur if it is not prevented.

WARNING

Hazardous situation in which death or serious injury could occur if it is not prevented.

CAUTION

Hazardous situation in which minor to moderate injury could occur if it is not prevented.

ATTENTION

Damage to equipment could occur.

Note

Useful tips and recommendations, as well as information on efficient and fault-free operation.

2.2 Intended use

The ghostONE is a Wallbox with network capability. It is used for charging electric vehicles that comply with the generally applicable standards and directives for electric vehicles.

It is suitable for stationary use indoors and outdoors and in private and semi-public spaces for operation within the defined electrical and environmental specifications, see [Technical data](#).

The Wallbox may only be used as a supply line, control unit and charging cable combination.

Any other use is classed as not intended.

Non-stationary operation of the Wallbox is prohibited.

The following are not permitted:

- Mechanical or electrical modifications to the Wallbox, excluding those described in these instructions.
- Use of additional equipment such as multiple sockets or cable reels.

Note

For information on whether the 1-/3-phase switching may be used with the vehicle, see the vehicle manufacturer's documentation or contact the vehicle manufacturer.

2.3 Safety information for operation

- Protect against direct exposure to weather conditions.
- Do not drive over or twist the charging cable.
- Only operate the Wallbox in a stationary location.
- Do not use any extension leads, cable reels, multiple sockets or adapters during operation.
- Do not insert any objects into the Wallbox.
- Do not place any objects on the Wallbox.
- Avoid the Wallbox coming into contact with liquids.

- Read the instructions carefully and in full and observe and follow the warning notices.
- Observe any country-specific restrictions and regulations.
- Store the operating instructions in a location that is easily accessible to the operator/user.
- Only use the designated accessories.
- Observe the ambient and storage conditions, see [Technical data](#).
- Do not stick anything onto the Wallbox or block it with objects.
- Do not remove, manipulate or bypass the manufacturer's seal or lock.
- Persons with a cardiac pacemaker must maintain a distance of at least 60 cm and persons wearing a defibrillator a distance of at least 40 cm from the RFID scanner, identifiable by the symbol on the front panel.
- Symmetrical network operation must be guaranteed in 1-phase operation. The detailed requirements regarding unbalanced load regulations can be found in the respective country-specific requirements. See assembly and installation instructions, "Setting the charging current".

 Note

eSystems MTG GmbH only accepts responsibility for the delivery condition of the Wallbox and for work performed by the specialist personnel approved by eSystems. The warranty term set out in the contract is applicable.

3 Product overview

3.1 Design

The ghostONE has the following design:



Abb. 1: Design (versions with permanently connected charging cable)

1	Housing
2	Decorative cover
3	Front panel
4	Energy meter (optional)
5	Charging cable

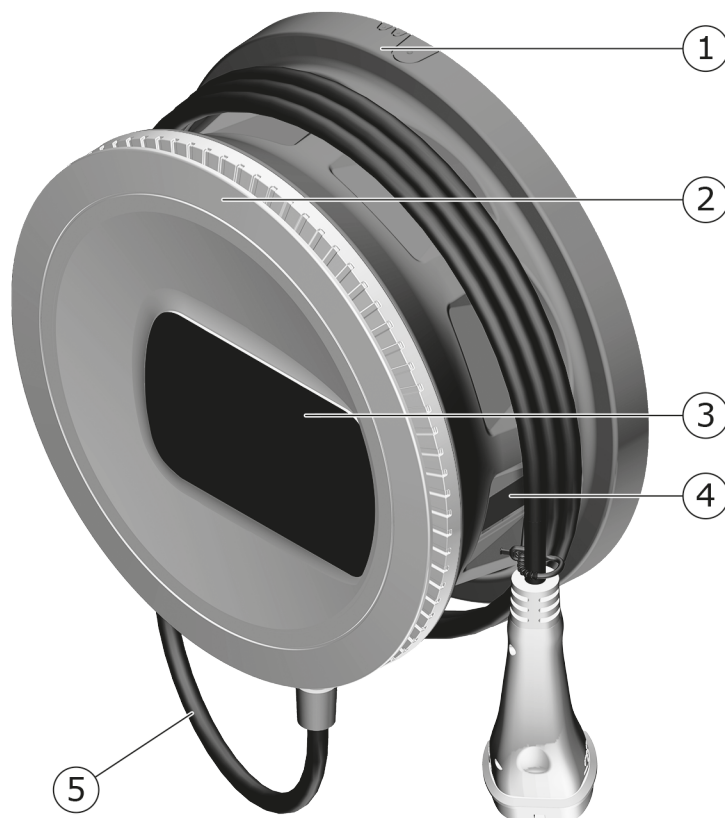

Abb. 2: Design (version with socket)

1	Housing
2	Decorative cover
3	Front panel
4	Energy meter (optional)
5	Socket type 2

Note

For information about the front panel, see [Front panel](#).

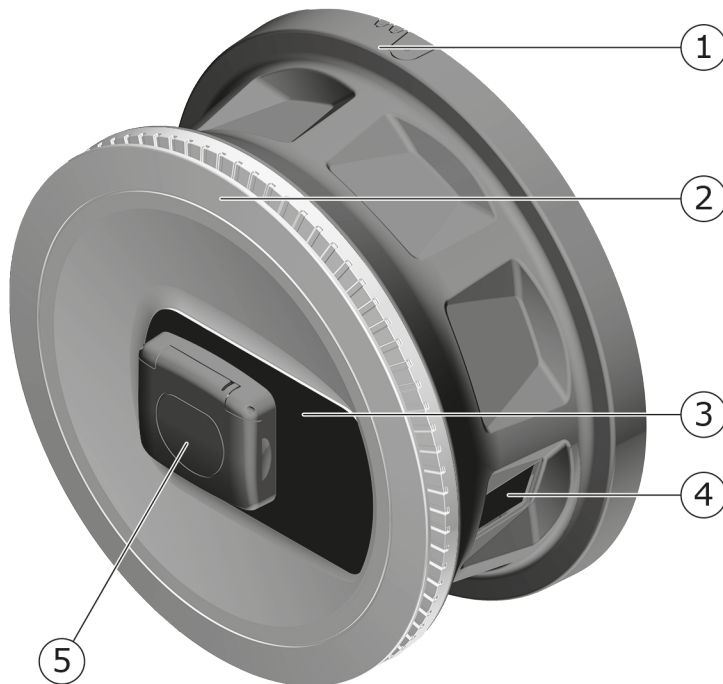
3.2 Functions

Note

For information on whether the 1-/3-phase switching may be used with the vehicle, see the vehicle manufacturer's documentation or contact the vehicle manufacturer. See [Technical data](#).

The AC ghostONE has network capability and provides the following functions:

Function	Description
Intelligent charging functions	<ul style="list-style-type: none"> • Smart charging using ISO 15118 • EEBUS
Remote control interfaces	<ul style="list-style-type: none"> • Web app • Backend server via OCPP 1.6 • Backend server via OCPP 2.0.1 (with future software update)
Authentication and authorisation	<ul style="list-style-type: none"> • Plug & Charge • Auto charge • Free-Charging • RFID • Web app • Remote via OCPP
Connectivity	<ul style="list-style-type: none"> • Ethernet • WiFi hotspot • WiFi client • LTE (optional)
Consumption measurement	<ul style="list-style-type: none"> • Integrated • Optional <ul style="list-style-type: none"> ◦ MID-compliant energy meter or ◦ MID-compliant energy meter and entire device compliant with German calibration law
Residual direct current detecting device (RDC-DD)	<ul style="list-style-type: none"> • DC 6 mA
Software updates	<ul style="list-style-type: none"> • Local update from network server • Update via OCPP • Over The Air update using special download server

Rating plate



Abb. 3: Rating plate (example)

1	Manufacturer
2	Model name
3	Part number
4	Serial number
5	Date of manufacture
6	Hardware status
7	Software version
8	Power and nominal current -> Connection type
9	Mains voltage
10	Power, nominal current and mains frequency
11	Residual direct current detecting device (RCD-DD)
12	Foreign body protection (IP protection type)
13	Ambient temperature
14	Disposal information, see also Disposal
15	Warning in case of improper use: Danger due to electrical voltage

16a	Data in accordance with Wallbox certification under German calibration law
16b	Nominal current range of the energy meter
16c	Data in accordance with EU Directive 2014/35/EU
16d	Data in accordance with EU Directive 2014/53/EU
16e	Data in accordance with UK Regulation S.I. 2016 No. 1101
17	Observe operating instructions
18	Surface of the Wallbox can become hot
19	Accuracy class A
20	Maximum altitude
21	Protection class I

3.3 Items supplied

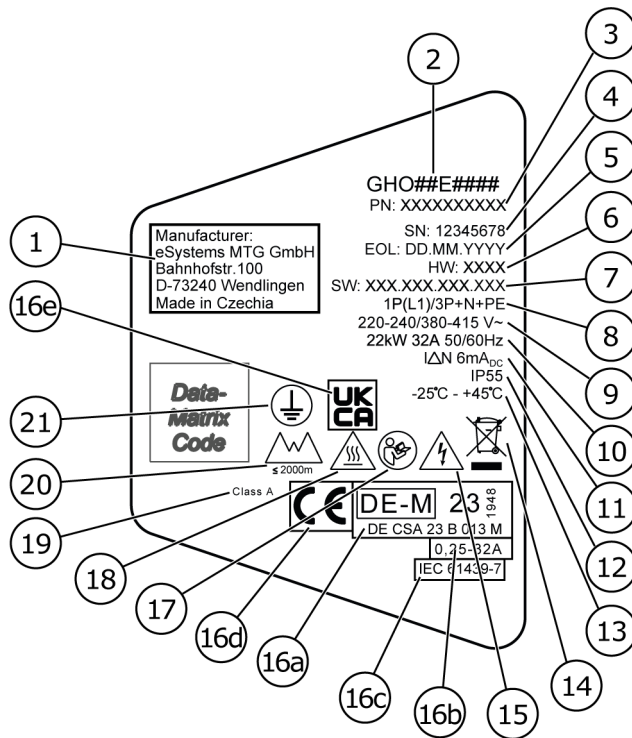
① Note

More screws may be supplied than are necessary.

Component	Quantity
Wallbox (consisting of housing, cover, decorative cover)	1
Charging cable "Type 2" (optional)	1
Assembly and installation instructions	1
Quick start guide	1
Access data letter	1
Drilling template	1
RFID chip	2
Operator's seal (for versions according to German calibration law)	2
Cable entry plate KEL-SCDP 40	1
Cable entry plate KEL-DP 20-4-1	1
Hanger bolt BSCR M8/120	4
Self-adhesive sealing washer	4
Flat washer ISO 7089 - 8.4	4
Hexagon nut M8x9.5	4
Cable gland (not for version with socket)	1
Cable gland nut M25x1.5 (not for version with socket)	1

Component	Quantity
Heat shrink tubing	1
Strain relief	1
Screw 4x17 (not for version with socket)	2
Screw 5x22 (for version with permanently connected charging cable)	4
Screw 5x22 (for version with socket)	7
Screw 4x13	1
QR code sticker (for version according to German calibration law)	1

Check items supplied

1. Directly after unpacking, check that all components are included and undamaged.
2. In case of damage or missing components, contact support, see rear of these instructions.

3.4 Access data

Along with the Wallbox you will receive a letter containing the access data. It includes the following information:

Information	Meaning
OEM Part Number	Part number of the Wallbox
Serial Number	Serial number of the Wallbox
Ethernet MAC Wi-Fi MAC Access Point Wi-Fi MAC Client	Global unique identification of the components in the Wallbox with network capability (Ethernet connection, WiFi hotspot, WiFi client connection).
Wi-Fi SSID	Wallbox SSID WiFi code As delivered, the WiFi code contains a device-specific sequence of numbers. The user can change this in the web app.
Wi-Fi PSK	Network key (password) for access to the Wallbox WiFi hotspot

Information	Meaning
Hostname	<p>Identification of the Wallbox in the web app, as an alternative to entering an IP address.</p> <p>As delivered, the host name contains a device-specific sequence of numbers. The user can change this in the web app.</p>
Password Standard User	Password for the standard user role, for use in day-to-day operation
Password Service User	Password for the service user role, for use during installation of the Wallbox and for making system settings.
PUK	Personal unblocking key if the password is no longer known.
External metering device public key	For the version according to German calibration law only, for electronic verification of billing data received.
QR-Code	For access to the Wallbox via the web app.

ⓘ Note

- Store the access data securely.
- If the access data is lost or the envelope is damaged, contact Support.

ⓘ Note

- Always store the access data letter or any access data changed at a later date in a secure location.

When delivered, the Wallbox already has individual access data.

3.5 Wallbox web app

The web app has the following design:



Abb. 4: Design of web app

- | | |
|---|--|
| 1 | 2-level navigation |
| 2 | View with information or configuration options |
| 3 | Title bar with login information |

4 Front panel

4.1 Front panel

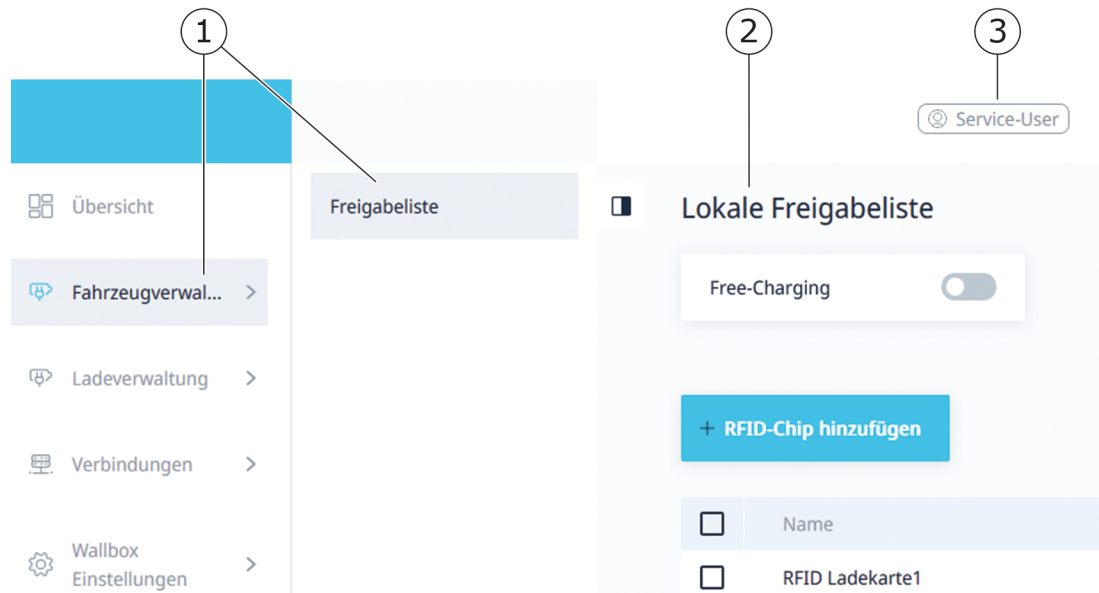
The following illustration provides an overview of the displays and controls on the front panel:



Abb. 5: Front panel overview (left: versions with permanently connected charging cable and right: version with socket)

1	Network connection LED
2	Brightness sensor
3	Charge level LED
4	LED with button for operating/error status
5	Cloud/backend connection LED
6	RFID sensor with integrated LED
7	Socket for type 2 charging cable (for version with socket only)

4.2 Displays and controls

LEDs

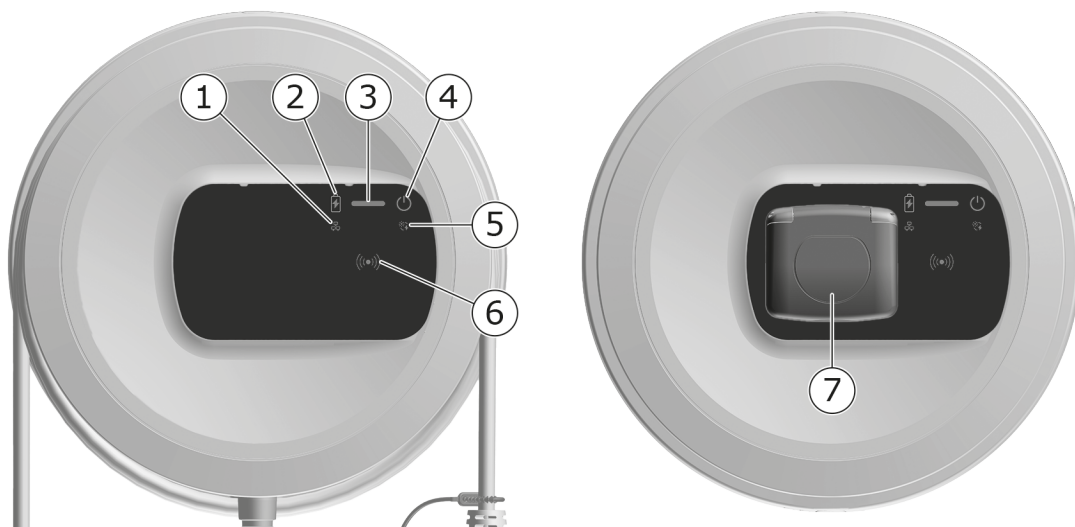
The following LEDs are provided on the front panel, see also [Front panel](#). They indicate the following information:

Type of information	Colour	Meaning
Charge level	White, continuous	No vehicle connected or the vehicle has not yet been detected.
	White, pulsing	Preparing to charge.
	Yellow, pulsing	Waiting for charging approval.
	Green, pulsing	The vehicle is being charged.
	Green, continuous	Charging is complete.
		Connection to the backend server via OCPP. Public charging configured.
	Green, flashing	Charging break (e.g. for vehicles with advanced communication or 1-/3-phase switching).
	Red	Charging error.
Operating / error condition		For further detailed information, see Error categories .
	White, continuous	The Wallbox is ready to operate (default condition).
	White, flashing	Software update is available.
	White, pulsing	Software update in progress.
	Blue, pulsing	Resetting factory defaults complete.
	Blue	Error that does not interrupt or prevent charging.
	Yellow	Charging is not currently possible, or has been interrupted and can be continued after fixing the error.
	Red	Error or warning that interrupts charging and requires a restart of the Wallbox.

Type of information	Colour	Meaning
RFID		Default condition: Off
	White, flashing	An RFID chip is required.
	White, pulsing	An RFID chip has been detected and the read/write operation has been initiated.
	Green (5 seconds)	An RFID chip has been successfully detected.
	Red (2 seconds)	RFID chip has not been detected or is not registered for the Wallbox.
Network connection	Off	No active connection.
	Green	Active connection.
	Yellow, flashing	Establishing connection.
Cloud/backend connection	Green, continuous	OCPP is configured and available. Connection to the backend server via OCPP is active. In the version in accordance with German calibration law, public charging in accordance with German calibration law is also configured.
	Off	OCPP is not configured and not available. In the version in accordance with German calibration law, public charging in accordance with German calibration law is not possible.
	Yellow, flashing	OCPP is configured, but cannot currently be used. In the version in accordance with German calibration law, public charging in accordance with German calibration law is not possible.

Valid for the version according to German calibration law

If public charging in accordance with German calibration law is enabled, the assigned pagination ID is always shown together with other information on the LCD of the energy meter. The pagination ID is particularly relevant for billing purposes.

Button

The button on the front panel performs the following functions:

Operation	Meaning
▪ Press button for 8 seconds.	Restart Wallbox (power-on-reset)
▪ Briefly press button.	Exit energy saving mode.

RFID sensor

The RFID sensor allows the following read and write operations from/to the user's RFID chips:

- Registering an RFID chip for charging
- Authorising charging using a registered RFID chip

Socket

Note

The socket is available depending on the version.

The front panel has a type 2 socket in accordance with IEC 62196. The socket can be locked and unlocked, see [Configuring the socket locking/unlocking](#).

- Only use the appropriate connector:

Supply type	AC
Standard	EN 62196-2
Design	Type 2
Connector type	Connector and socket
Voltage range	≤ 480 V RMS
Identification	

5 Assembly and installation

Further information

For detailed information about assembly and installation of the Wallbox, refer to the Assembly and installation instructions.

5.1 Attaching the lock/lead seal

1. Remove the decorative panel: Loosen the screw (4x13) for attaching the decorative panel from below.

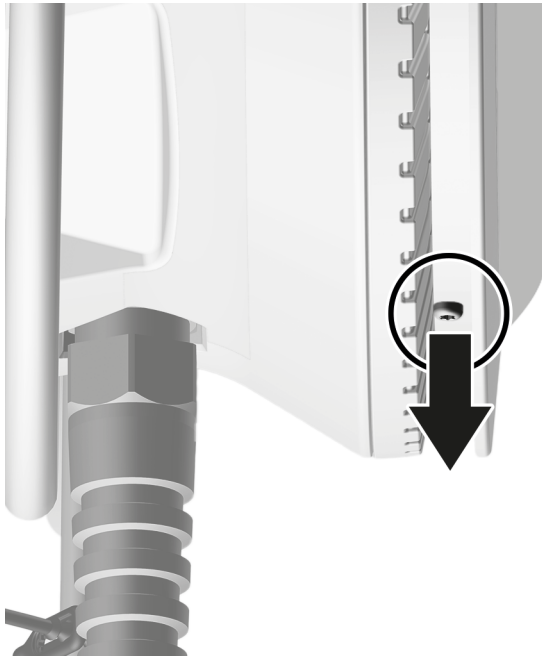

5 Assembly and installation

2. Unhook the housing (1) and at the top release the decorative panel from the clips (2).

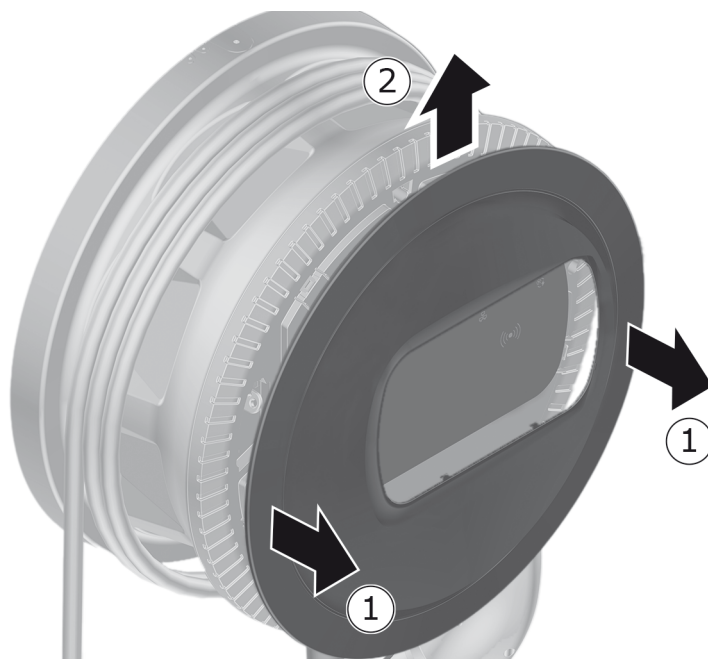

3. Remove the lock/lead seal from the clip or attach to the clip.

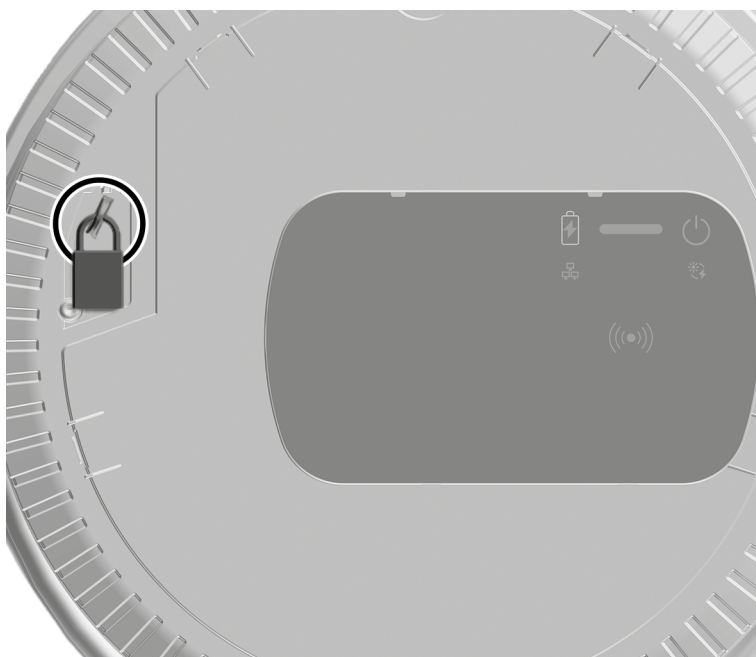

6 Commissioning and configuration

① User roles

To make settings when installing the Wallbox and to make system settings on the Wallbox, logging in as a service user is necessary. These settings are indicated by "For service user only".

The standard user role is intended for use in day-to-day operation of the Wallbox.

6.1 Connecting to the Wallbox using the web app

① Note

When accessing the web app, the web browser may display a warning stating that the page poses a security risk or that a secure connection cannot be established (depending on the browser). Depending on the web browser, the "Advanced" screen can be used to enable access to the web app via an additional button or link.

1. Keep the access data letter to hand.
2. Find the list of available WiFi devices on the laptop, tablet or smartphone.
3. Select the Wallbox from the list of available WiFi devices using the WiFi code (SSID) from the access data letter.
4. Establish a connection with the selected Wallbox.
If a connection could not be established, see assembly and installation instructions, "Commissioning, No connection to web app established via WiFi."
5. Enter the WiFi password for the Wallbox (network key) from the access data letter.
6. After successfully connecting to the WiFi hotspot, open the web browser.
7. Enter the host name of the Wallbox from the access data letter in the address bar.

The login view is displayed in the web app with a login option.

ⓘ Note

If the web app is not opened, enter the IP address of the Wallbox 10.0.2.1 in the web browser instead of the host name. For a connection via Ethernet, see [Ethernet](#).

8. Select standard user as the user role.

ⓘ Note

System settings can only be made as the service user.

9. Enter the password for the standard user (from access data letter).

After a successful login, the **Overview** is displayed.

6.2 Configuring wallbox network settings

6.2.1 Ethernet

ⓘ For service user only

ⓘ Prerequisite

To connect the Wallbox via Ethernet, an Ethernet cable must be installed. See assembly and installation instructions.

1. Connect the Wallbox to the network using an appropriate Ethernet cable.

The Wallbox can also be connected directly to a mobile device via Ethernet.

If necessary, check the network configuration if the switch used requires this for new network devices.

2. Open your preferred web browser and connect to the Wallbox using the host name.
3. Log in as a service user on the web app.
4. Select the **Connections, Ethernet** option in the navigation. The **Ethernet** screen and the corresponding MAC address are displayed.
5. Enable/disable **Automatic address assignment (DHCP)**. The IPv4 or IPv6 address can only be entered if **Automatic address assignment (DHCP)** is disabled. Otherwise these addresses are only displayed.
6. To configure an IPv4 address, enter the following:

IPV4 address, IPV4 subnet mask, IPV4 gateway

7. To configure an IPv6 address, enter the following:

IPv6 address, Length of IPv6 prefix, IPv6 gateway

8. If necessary, change the host name of the Wallbox and the pre-assigned **DNS server address**.

9. To apply the changed settings, select **Connect Ethernet**. If successful, the message **Change applied** appears.

No connection to web browser established using Ethernet cable

If a connection could not be established, check the following:

1. Check whether the Wallbox is connected to a network switch or an appropriately configured computer and that it is active and is not showing any errors.

2. In the network environment display, check whether the Wallbox is displayed.

- **If necessary, restart the switch or laptop.**
- Check the cable and unplug and plug in again if necessary.
- If necessary, consult the network administrator.

3. If connecting using the host name, check the spelling carefully.

6.2.2 WiFi hotspot

The Wallbox offers a WiFi hotspot so that you can connect directly to it wirelessly without additional network devices. The Wallbox web app can be accessed via the connection.

Note

Only WiFi channels that are permitted based on the country code are approved.

The WiFi hotspot can remain active in client mode.

If the WiFi hotspot is disabled, access to the Wallbox is no longer possible if the Wallbox is not connected to a WiFi client or Ethernet network. Reactivation is then only possible by resetting to factory defaults (Factory-Reset), see assembly and installation instructions, "Resetting the Wallbox using the rotary switch".

1. Connecting via WiFi hotspot

1. Keep the access data letter to hand, see [Access data](#).
2. Find the list of available WiFi devices on the mobile terminal.

3. Select the Wallbox from the list of available WiFi devices using the WiFi code (SSID) from the access data letter.

Establish a connection with the selected Wallbox.

4. If a connection cannot be established, see [No connection to web app established via WiFi](#).
5. Enter the WiFi password for the Wallbox (network key) from the access data letter.
6. When the connection has been established successfully, open the web browser.
7. Enter the host name of the Wallbox from the access data letter in the address bar.

The **Overview** for guest access is displayed in the web app together with a login function, see [Authenticating on the Wallbox](#).

Note

If the web app is not opened, enter the IP address of the Wallbox 10.0.2.1 in the web browser instead of the host name.

No connection to web app established via WiFi

If a connection could not be established, the following items should be checked:

1. Work closer to the Wallbox.
The mobile terminal should not be too far away from the Wallbox as the WiFi module in the Wallbox only has a limited range.
 2. Check the mobile terminal's WiFi module and the connection to the network or Internet.
 3. Check the security settings on the mobile terminal (such as fire-wall, network settings).
If prompted, confirm the Wallbox as a trusted device.
 4. Ensure that the access data (password and host name) is entered correctly, particularly the password (capitalisation).
2. Log in using the web app.
 3. Select the **Connections, Hotspot** option in the navigation. The **Hotspot** screen is displayed.
 4. If necessary, enable the **Hotspot** option.
 5. Enter the **SSID** and **Network key (password)**.
 6. Enable **WPA2** (default setting) or **WPA3**.

7. Click **Save** to confirm.

6.2.3 WiFi client

ⓘ For service user only

ⓘ Note

The WiFi hotspot can remain active in client mode.

ⓘ Note

As a WiFi client, the Wallbox is integrated into the local network. This can then be used to access the Wallbox.

ⓘ Note

The Wallbox is fitted with an internal firewall and security mechanisms for IP-based network communication.

- Only install the Wallbox in private networks and use a firewall.
- Use either WPA2 (default setting) or WPA3 for a secure WiFi connection.
Operation in WiFi mode is not possible with protocols that are unencrypted or do not meet the latest security standards, for example WEP.

Selecting a detected network

To connect the Wallbox to a different WiFi network as a client, select the network as follows:

1. Log in using the web app.
2. Select the **Connections, WLAN** option in the navigation. The **WiFi connection** screen is displayed and shows all available WiFi networks, sorted by WiFi signal strength.
3. Click the right arrow for one of the detected networks and enter the corresponding **Network key (password)**.
4. Confirm with **Connect WiFi**.

Alternatively, for networks that do not communicate their SSID for security reasons and therefore are not displayed in the network list:

1. To add a WiFi network, select the **Add WiFi** option in the **WiFi connection** screen.
2. Enter the corresponding **SSID** and the **Network key (password)**.
3. Confirm with **Connect WiFi**.

Disconnecting the WLAN connection

1. Select the **Connections, WLAN** option in the navigation.
2. In the **WiFi connection** screen, select **Disconnect** for the connected WiFi.

6.2.4 LTE

ⓘ For service user only

ⓘ Note

This function is only available for selected Wallbox versions.

ⓘ Prerequisite

To connect the Wallbox via LTE, a SIM card for LTE modem use is required. This SIM card has been inserted in the relevant slot during installation of the Wallbox, see assembly and installation instructions.

1. Log in using the web app.
2. Select the **Connections, LTE** option in the navigation.
3. On the **LTE connection** screen, select the **Enable LTE** option if necessary.
Default setting: LTE is enabled.
4. If the status **PIN required** is displayed for **SIM**, click the right arrow, enter the required PIN and confirm with **Send PIN**.

The following information is displayed:

- Signal strength of the LTE connection using a bar chart
- **Network connection:** Name of the connected network
- Connection status: **Connected, Connecting, Connected to unauthorised provider, Not connected, Reverting to 2G, SIM blocked, PIN required, No SIM detected, Error, Not installed**
- Parameters for LTE identification:
IMSI: International Mobile Subscriber Identity
IMEI: International Mobile Equipment Identity
ICCID: Integrated Circuit Card IdentifierNetwork mode

6.3 Authenticating on the Wallbox

ⓘ Prerequisites for successful login as standard user

The service user has completed the configuration process, see assembly and installation instructions, "Configuring the Wallbox".

1. Get the password for the Standard user from the access data letter, see [Access data](#).
2. In the **Login** view select the Standard user role, enter the corresponding password and confirm.

ⓘ Note

Ensure that the access data is spelt completely correctly, paying particular attention to capitalisation.

After five incorrect password entries, there is a delay before you can make another attempt.

3. The first time you log in as a standard user, read and accept the disclaimer and the information on protection of personal data.

After successful login, the **Overview** screen for the Wallbox is displayed, showing a compact view of the most important operating statuses and measured values, see also [Information in the overview](#).

ⓘ Note

The Wallbox must be configured when logging in for the first time or when logging in after a factory reset (Factory-Reset), see assembly and installation instructions, Configuring the Wallbox.

7 Operation

7.1 Login/logout

ⓘ Note

- In everyday operation, use the standard user role wherever possible to prevent system settings from being accidentally changed.

ⓘ Note

When accessing the web app, the web browser may display a warning stating that the page poses a security risk or that a secure connection cannot be established (depending on the browser). Depending on the web browser, the "Advanced" screen can be used to enable access to the web app via an additional button or link.

Logging in using the web app

ⓘ Prerequisite

An existing connection to the WiFi hotspot of the Wallbox or the device that is to be connected to the Wallbox is on the same network (WiFi or Ethernet) as the Wallbox.

1. Open the web browser and enter the host name from the Wallbox access data letter in the address bar to start the web app.

ⓘ Note

If the web app is not opened, enter the IP address of the Wallbox 10.0.2.1 in the web browser instead of the host name.

2. In the login screen, on the **Standard** tab for a standard user or the **Service user** tab for the service user, enter the personal password from the access data letter or the password you have set yourself and confirm.

ⓘ Note

Ensure that the password is spelt completely correctly, paying particular attention to capitalisation. After five incorrect password entries, there is a delay before you can make another attempt.

The **Overview** is displayed, see [Information in the overview](#).

Logging out from the web app

- Select the user icon in the title bar. The logout screen is displayed.

- Select **Logout**.

The login screen is displayed.

ⓘ Note

If you have not communicated with the Wallbox using the web app or front panel for longer than 20 minutes, you will automatically be logged out.

7.2 Information in the overview

- To display the system information, select the **Overview** option in the navigation.

The following system information is displayed:

- Information about the connected vehicle:
 - Name and picture, if uploaded by user/operator
 - Brand and model if the vehicle transmits this data
- Charging status:
 - **No vehicle connected**
 - **Charging approval in process**
 - **Vehicle is charging**
 - **Pause charging**
 - **Charging complete**
 - **Charging error**
 - **Charging not possible at the moment**
 - **1-/3-phase**
- **Charging energy** currently being used to charge the vehicle
- **Maximum charging current (A)**
- **1-/3-phase switching**, explanatory text is displayed in web app when enabling/disabling
- **Device data** for the energy meter: **Manufacturer/Type, Status, Hardware version, Software version, Serial number, Calibration date, Operating times, Meter reading**

Only for version according to German calibration law: The data matrix code for the energy meter is displayed under **Public key** (Public-Key).
- **Energy consumption** in the form of a charging curve:

A graphical representation of the energy consumption in kWh can be seen for the charging in progress.

- Network status display for all networks: **Ethernet, WiFi, LTE, OCPP, HEMS**

Possible status: **Connected, Not connected, Not set**

The following actions are available if a vehicle has been detected or charging is in progress:

- If the connected vehicle is not yet in the approved list, select **Add to approved list** to add it to the approved list.
- Select **Start charging** to start charging the connected vehicle once, see also [Starting charging](#).
- Select **Stop charging** to stop charging, see also [Finishing charging](#).

7.3 Charging a vehicle

7.3.1 Starting charging

1. Only for version with socket: Plug the charging cable into the socket on the Wallbox.

Note

The connector may be automatically locked when a vehicle connection is detected, see [Configuring the socket locking/unlocking](#).

2. Plug in the charging cable on the vehicle.

The Wallbox creates a charging approval and starts charging in one of the ways described below:

Note

If OCPP is enabled and a connection to the OCPP backend server has been established, the charging approval is always created by the OCPP backend server. If OCPP is enabled, Free-Charging of the Wallbox is disabled.

Special feature: The CPO can continue enabling Free-Charging via OCPP.

Authorisation	Description	Prerequisites
Free-Charging	The Wallbox creates a charging approval without any interaction by the user or the vehicle.	<ul style="list-style-type: none"> The option for charging without authentication is enabled for the Wallbox.
RFID	The user holds up an RFID chip to the sensor on the front panel of the Wallbox.	<ul style="list-style-type: none"> The RFID chip has been registered on the Wallbox. The RFID chip is held up to the sensor and detected by the Wallbox.
Plug & Charge	Vehicles with advanced communication in accordance with ISO 15118 can authenticate themselves on the Wallbox using a certificate without the user having to perform any further actions on the Wallbox.	<ul style="list-style-type: none"> Vehicle supports advanced communication and it is enabled on the vehicle. PLC vehicle connection is enabled for the Wallbox. Vehicle Plug & Charge certificate is identified as valid by the Wallbox.
Web app	The user can create a charging approval using the web app.	<ul style="list-style-type: none"> The user has opened the web app and selected Overview, Start charging.
Auto charge	Vehicles with advanced communication in accordance with ISO 15118 can authenticate themselves on the Wallbox using the vehicle address without the user having to perform any further actions on the Wallbox.	<ul style="list-style-type: none"> Vehicle supports advanced communication and it is enabled on the vehicle. PLC vehicle connection is enabled for the Wallbox. Vehicle has been registered on the Wallbox with its vehicle address.

Authorisation	Description	Prerequisites
Remote	The user can create a charging approval using their CPO app.	<ul style="list-style-type: none">• The user has installed the CPO app.• OCPP backend connection is enabled for the Wallbox and has been established.• Remote authentication option is enabled for the wallbox.

The charge level LED on the front panel lights according to the charge level, see [Displays and controls](#). The charge level is displayed in the **Overview** in the web app, see [Information in the overview](#).

7.3.2 Charging with RFID chip

Prerequisites

- The RFID chip has been registered and added to the approved list for the Wallbox, see [Adding an RFID chip to the approved list](#).
- The vehicle is connected to the Wallbox, see [Starting charging](#).

DANGER

Risk of injury due to RFID sensor for persons with cardiac pacemaker or defibrillator

- If you use a cardiac pacemaker, maintain a distance of at least 60 cm from the RFID sensor on the front panel.
- If you use a defibrillator, maintain a distance of at least 40 cm from the RFID sensor on the front panel.

1. Hold up the RFID chip to the RFID sensor on the front panel of the Wallbox.

If it is detected successfully, an acoustic signal sounds, the RFID sensor LED briefly lights up green and charging begins.

Note

If the RFID chip has not been correctly detected, the RFID sensor LED on the front panel lights up red.

- Hold up the RFID chip to the sensor again.
- Check that the RFID chip is compatible with the Wallbox and is registered.

2. The charge level LED on the front panel lights up green, see [Displays and controls](#). The charge level is displayed in the **Overview** in the web app, see [Information in the overview](#).

7.3.3 Pausing charging

Note

This function is only available for vehicles with advanced communication.

Charging pauses are controlled by the ISO 15118 protocol based on a charging plan.

The charge level LED on the front panel flashes green, see also [Displays and controls](#). The charge level is displayed in the **Overview** in the web app, see [Information in the overview](#).

7.3.4 Finishing charging

Charging is automatically stopped when the vehicle battery is fully charged.

Interrupting charging

In addition, the user is able to interrupt charging as follows:

- In the web app, select the **Overview, Stop charging** option in the navigation to stop charging.

The charge level LED on the front panel then lights up continuously green, see also [Displays and controls](#). The charge level is displayed in the **Overview** in the web app, see [Information in the overview](#).

When charging is finished:

1. Unplug the charging cable on the vehicle.
2. Only for version with permanently connected charging cable: Securely store the charging cable on the Wallbox.

Only for version with socket: Unlock the socket if necessary, see [Configuring the socket locking/unlocking](#).

3. Only for version with socket: Unplug the charging cable from the socket on the Wallbox and store securely.

Note

The connector may be automatically locked when a vehicle connection is detected, see [Configuring the socket locking/unlocking](#).

7.3.5 Configuring the PLC connection to the vehicle

For vehicles with advanced communication in accordance with ISO 15118, a vehicle-to-grid (V2G) connection to the Wallbox can be enabled (default setting) or disabled using PLC.

Note

If V2G is enabled and used with a vehicle that does not support advanced communication, there may be delays in starting charging or it may not be possible to start charging at all. If you are using a vehicle of this type, the PLC connection should be disabled.

- Log in using the web app.
- Select the **Connections, PLC** option in the navigation. The **Vehicle with advanced charging function (PLC)** screen is displayed.
- Enable/disable **Vehicle connection via PLC**.

7.3.6 Charging information and settings

Configuring the maximum current

1. Select the **Charging management, Charging settings** option in the navigation.

Note

Manually specifying the maximum charging current can be useful if no energy management system is installed.

2. On the **Charging current** screen, configure the value for the **Maximum charging current (A)**.

The maximum value that can be set is automatically limited by the current-carrying capacity of the vehicle and the mains connection.

The current-carrying capacity of the mains connection is configured during installation of the Wallbox using the rotary switch, see assembly and installation instructions, "Setting the charging current".

7.4 1-/3-phase switching

ⓘ Note

For information on whether the 1-/3-phase switching may be used with the vehicle, see the vehicle manufacturer's documentation or contact the vehicle manufacturer.

ⓘ Note

Note that symmetrical network operation is guaranteed in 1-phase operation. The detailed requirements regarding unbalanced load regulations can be found in the respective country-specific requirements. The limitation of the charging current can be set directly in the vehicle or alternatively via the Wallbox. Setting is carried out by:

- Electrical engineer: via the rotary switch by limiting the charging current, see assembly and installation instructions, "Setting the charging current".
- User: see [Configuring the maximum current](#).

For vehicles that only support charging without advanced communication, a minimum amperage of 6 A per phase is required to charge the vehicle. When using a photovoltaic system, for example, it is possible that this minimum amperage cannot be provided by the photovoltaic system due to environmental conditions. In this case, phase switching to a 1-phase supply can be useful to avoid having to draw electricity from the grid (photovoltaic system surplus charging).

1. Select the **Phase switching (1/3)** menu symbol in the navigation.

The following setting/display options are displayed:

- **Enable phase switching (1/3)**

This enables phase switching and thus switching can be requested by pressing the option button (1-phase / 3-phase).

- **Current phase setting**

There are three possible states: 1-phase, 3-phase or continuous switching.

ⓘ Note

Note that phase switching takes at least one minute.

During a switching process, further switching cannot be requested again.

7.5 Enabling / disabling Free-Charging (charging without authentication)

ⓘ For service user only

Free-Charging (charging without authentication) allows charging without local authorisation or authorisation from the backend server.

1. Select the **Vehicle management, Approved list** option in the navigation. The **Local approved list** screen is opened.
2. Enable/disable **Free-Charging**.

7.6 Managing the approved list

ⓘ For service user only

The web app can manage up to 1,000 individual vehicles in the approved list.

ⓘ Note

The approved list is only used if there is no OCPP connection.

ⓘ Note

Wallbox is not compatible with all backends. The list of compatible backends is available from the Wallbox supplier.

7.6.1 Adding an RFID chip to the approved list

 **DANGER**

Risk of injury due to RFID sensor for persons with cardiac pacemaker or defibrillator

- If you use a cardiac pacemaker, maintain a distance of at least 60 cm from the RFID sensor on the front panel.
- If you use a defibrillator, maintain a distance of at least 40 cm from the RFID sensor on the front panel.

ⓘ Note

In addition to the RFID chips supplied, all standard RFID chips with NFC forum type 1-5 can be used.

1. Select the **Vehicle management, Approved list** option in the navigation. The **Local approved list** screen is displayed.

2. Select **Add RFID chip**. The **Set up RFID chip** screen is displayed.
3. Hold up the RFID chip to the RFID sensor on the front panel of the Wallbox and select **Read RFID chip**.

As soon as the RFID chip has been detected, the identification of the RFID chip (UUID) is displayed in the **Set up RFID chip** screen. In addition, an acoustic response tone sounds and the RFID sensor LED briefly lights up green.

Note

If the RFID chip has not been correctly detected, the RFID sensor LED on the front panel lights up red.

- Hold up the RFID chip to the sensor again.
- Check that the RFID chip is compatible with the Wallbox.

4. Enter the name of the RFID chip in the **Name of RFID chip** field and confirm with **Save**.

The RFID chip is displayed as a registered chip on the **Local approved list** screen.

Alternatively: Setting up the RFID chip without holding it up to the sensor

Prerequisite

The user knows the UUID of the RFID chip.

- Select the **Vehicle management, Approved list** option in the navigation.
- Enter the **UUID (RFID chip identification)** and the **Name of RFID chip** on the **Set up RFID chip** screen.

7.6.2 Changing the RFID chip name in the approved list

1. Select the **Vehicle management, Approved list** option in the navigation. The **Local approved list** screen is displayed.
2. Select the RFID chip to be edited. The **Set up RFID chip** screen is displayed.
3. Change the name in the **Name of RFID chip** field and confirm with **Save**.

7.6.3 Removing an RFID chip from the approved list

1. Select the **Vehicle management, Approved list** option in the navigation. The **Local approved list** screen is displayed.
2. Select the RFID chip to be removed.
3. Select the menu icon and then select **Delete selected entries**.
The RFID chip is removed from the approved list.

7.7 Managing OCPP settings

7.7.1 Connecting the Wallbox via OCPP

ⓘ For service user only

ⓘ Note

Wallbox is not compatible with all backends. The list of compatible backends is available from the Wallbox supplier.

1. Select the **Connections, OCPP** option in the navigation. The **OCPP connection** screen is opened.
2. Enable **OCPP**. OCPP is disabled by default.
3. Make the following entries for the OCPP backend. This information is provided by the backend service provider.

ⓘ Note

The data required to configure the connection may differ depending on the backend service provider.

- **URL** of OCPP backend server
 - **Port** for OCPP backend
 - **OCPP version**
 - **User name**
 - **Password** of OCPP access point
 - Enable/disable **TLS encryption**. Default setting: Enabled
4. Enter the ID for the **charging point** in the **Charging point ID** field (mandatory) and the **EVSE ID** field (optional).
The CPO provides the EVSE ID.
 5. Select **Connect**.

Establishing connection. **Connection started** is displayed as the status and the **Disconnect** option is available.

6. Enable/configure the following optional settings:

- **Allow charging to start remotely:** Remote authorisation of charging, e.g. using the CPO app, allowed / not allowed. Default setting: Not allowed

For detailed information about the different types of authorisation, see [Starting charging](#).

- **Vehicle connection timeout** (in minutes and seconds): Time that the user has to plug the type 2 vehicle coupling of the charging cable into the vehicle connection before charging.

Permissible range of values: 15 – 180 seconds, default setting: 45 seconds

Disconnecting the OCPP connection

1. Select the **Connections, OCPP** option in the navigation. The **OCPP connection** screen is opened.
2. Select **Disconnect**. **Disconnected** is displayed as the status.

7.8 Managing smart charging / smart home

7.8.1 Configuring the Wallbox for a smart home EMS via EEBUS

ⓘ Note

The ghostONE supports home energy management systems (HEMSs) that are EEBUS-compatible.

Showing EEBUS-compatible devices / HEMS

- Select the **Connections, EEBUS-HEMS** option in the navigation.

The **EEBUS-HEMS** screen is displayed and shows all detected EEBUS-compatible devices / HEMS.

ⓘ Note

It is possible that other EEBUS-compatible devices will be available in addition to the HEMS.

The following information is displayed:

- Under **Paired EEBUS devices**: EEBUS devices paired with the Wallbox, if available.
- Under **EEBUS devices found**: List of all EEBUS devices found in the network.
- Under **Wallbox EEBUS setting: Name** of the EEBUS device found and **Name of EEBUS device (SKI)** (Subject Key Identifier).
- Status information:
 - Status of the connection to the HEMS: **Connected, Not connected**
 - Connection to device: **Connected, Not connected**
 - EEBUS connection status

Connecting an HEMS

ⓘ For service user only

1. Select the **Connections, EEBUS-HEMS** option in the navigation.
2. On the **EEBUS-HEMS** screen, under **EEBUS devices found** select the right arrow for the HEMS you want to connect.
3. To connect the HEMS, select **Pair**.
4. Hold down the corresponding button on the HEMS device for several seconds (push button pairing). Follow the instructions from the operating instructions for the HEMS.

Once the connection has been successfully established, the HEMS is displayed on the **EEBUS-HEMS** screen under **Paired EEBUS devices**.

Disconnecting from the HEMS

1. Select the **Connections, EEBUS-HEMS** option in the navigation.
2. On the **EEBUS-HEMS** screen, under **Paired EEBUS devices** select the right arrow for the HEMS you want to disconnect from the Wallbox.
3. Select the **Unpair** button on the **EEBUS-HEMS** screen.

The HEMS is removed from the list of paired HEMS on the **EEBUS-HEMS** screen and is displayed under **EEBUS devices found**.

7.9 Configuring general settings

7.9.1 Enabling/disabling eco mode

- Select the **Wallbox settings, Save energy** option in the navigation.
- On the **Save energy** screen, enable (default setting) or disable the **Eco mode** option.

If eco mode is enabled, the Wallbox goes into standby mode if there has been no user interaction via the web browser for 20 minutes, no active errors have occurred in the last 5 minutes and charging has not taken place. In this case, the LEDs on the front panel are not lit.

To wake up the Wallbox again, press the button on the front panel or connect a vehicle to the Wallbox.

7.9.2 Setting the LED brightness

ⓘ Note

- If automatic brightness setting is enabled (default setting) the brightness of the LEDs is controlled based on the measurements from the light sensor.
- If automatic brightness setting is disabled, the brightness of the LEDs is constant.

1. Select the **Wallbox settings, LED brightness** option in the navigation. The **Brightness** screen is opened.
2. Enable/disable **Set brightness automatically**.
3. Set the brightness using the slider.
 - With manual control: The brightness is permanently set to the selected value regardless of the measurements from the light sensor.
 - With automatic control: The brightness range can be set using two independent controllers.

7.9.3 Changing password

ⓘ Note

Depending on whether you are logged in as a standard user or service user, the corresponding password is changed.

1. Select the **Wallbox settings, Password** option in the navigation. The **Change password** screen is displayed.
2. Enter the existing password in the **Old password** field.
3. Enter the new password in the **New password** field and confirm by entering it again in the **Repeat password** field.

ⓘ Note

Observe the following rules when entering the password:

- Length: 8 – 14 characters
- The password must contain at least 1 number, 1 lower case letter, 1 upper case letter, 1 special character (@-_*!\$%#).
- The first character may not be a special character.

4. Click **Save** to confirm.

Logging in with PUK

1. If you have forgotten the password or have entered it incorrectly 5 times, select **Forgotten password**.
2. Take the PUK from the access data letter, see [Access data](#).
3. Enter the PUK and confirm with **Send PUK**.

ⓘ Note

- Ensure that the PUK is spelt correctly. After five incorrect entries, there is a delay before you can make another attempt.

After successful PUK entry, the **Overview** for the Wallbox is displayed, see also [Information in the overview](#).

4. Assign a new password.

7.9.4 Setting the language

ⓘ For service user only

1. Select the **Wallbox settings, Language** option in the navigation. The **Language setting** screen is opened.
2. Select the language in the **Language** list. The language of the web browser is the default setting.

7.9.5 Showing system settings

1. Select the **Wallbox settings, System information** option in the navigation.

The following types of system settings are displayed on the **System information** screen:

- **Network information**
- **Electronic rating plate**
- **Licences:** Licence information for software components used in the web app.
- **Privacy**

2. Select one of the setting types with the down arrow.

The corresponding screen showing detailed information is opened.

Type of system setting	Available information
Network information	
	Normal range
	Mains connection
	Maximum current-carrying capacity
Electronic rating plate	
Electronic rating plate	Make
	Part number
	Serial number
	Hardware status
Software version	Bundle version
	PWR software version: Power controller software version
	COM software version: Version of the communication controller software (comm controller)
Licences	
	Licence information for software components
Privacy	
	Privacy information

7.9.6 Setting units

① For service user only

1. Select the **Wallbox settings, Units** option in the navigation. The **Units** screen is opened.
2. Select the unit for the following parameters:
 - **Distance: Kilometres** (default setting), **Miles**
 - **Temperature: °C** (default setting), **°F**

7.9.7 Configuring the socket locking/unlocking

① For service user only

① Note

This functionality is only available for the Wallbox version with socket.

1. Select the **Wallbox settings, Socket** option in the navigation.
The **Locking status** is displayed on the **Socket** screen. The following statuses are possible:
 - **Not available**
 - **Unlocked**
 - **Locked**
 - **Error**
2. Under **Locking enable**, select when the socket is to be locked:
 - **When charging cable is connected**
 - **During active charging**

7.9.8 Enabling/disabling the earth monitoring system

① For service user only

⚠ DANGER**Risk of death due to electric shock**

Use of the Wallbox without an active earth monitoring system can cause electric shocks, short circuits, fires, explosions or burns.

- Only disable the earth monitoring system in non-earthed power networks (IT network).
1. Select the **Wallbox settings, Earth monitoring system** option in the navigation. The **Earth monitoring system** screen is opened. The earth monitoring system is enabled by default.
 2. Enable/disable the **Earth monitoring system**.

7.9.9 Showing the energy meter status

- Select the **Wallbox settings, Energy meter** option in the navigation. The **Energy meter status** screen is displayed.

The following data about the energy meter is displayed under **Device data**:

- **Manufacturer/Type**
- **Status:**
 - Active**
 - Connected**
 - Error**
 - Not installed** if the Wallbox is not fitted with an additional energy meter.
- **Hardware version**
- **Software version**
- **Serial number**
- **Calibration date**
- **Operating times** (in hours)
- **Meter reading** (in kWh)

Only for version according to German calibration law: The data matrix code for the energy meter is displayed under **Public key** (Public-Key).

7.10 Restarting the wallbox

1. Stop any current charging process.
2. Press and hold down the button on the front panel for at least 8 seconds.

After the restart, the LED self-test is performed. The LEDs light up in turn as follows:

- All LEDs red for one second
- All LEDs white for one second
- Charge level LED and error status LED white
- All other LEDs are not lit.

ⓘ Note

If a vehicle is connected, the charge level LED may be a different colour.

7.11 Resetting to factory defaults (Factory-Reset)

ⓘ For service user only

ⓘ Note

With the exception of the country code, all user settings are reset to the factory defaults, e.g. the approved lists.

1. Start the web app.
2. Select the **Wallbox settings, Factory defaults** option in the navigation.
3. Select **Reset to factory defaults** and confirm.

When the reset is complete the Wallbox is restarted.

ⓘ Note

If resetting to factory defaults (Factory-Reset) using the web app is not possible, the Wallbox can alternatively be reset using a special setting on the rotary switch. This setting may only be made by qualified specialist personnel. See assembly and installation instructions, "Resetting the Wallbox using the rotary switch".

7.12 Updating the software

7.12.1 Software update information

Display on the front panel

ⓘ Note

These displays are only visible if there are no active errors in the Wallbox.

- If the error LED is flashing white, a software update is available.
- During the software update, all of the LEDs light up red for a while.

ⓘ Security updates

To get information about security updates and to enable them to be installed on the Wallbox, an Internet connection through your local network is required. It is also possible to install a local security update on the Wallbox if required.

You can find further information and contact addresses in the **Cyber Security** area of the eSystems website.

Information in the web app

- Select the **Wallbox settings, Software update** option in the navigation.

The following information/functions are available on the **Software update** screen:

ⓘ Note

If the Wallbox is connected via OCPP, the following functions are disabled and the software is downloaded automatically.

- Enable/disable **Automatically download update**.
Enabled: Default setting. The software checks for available updates and they are downloaded automatically.
Disabled: The software checks for available updates and displays a message. The download then has to be started manually.
- Enable/disable **Automatically install update**.
Enabled: If a software update has been downloaded, the Wallbox installs it automatically.
Disabled: The installation can be delayed until a later time. Installation of a software update is only started when requested by the user.
- **Local update** enables you to select a file saved locally.

- For manual software updates: Select **Install update** to manually start installation of the software update.
- The following information is displayed under **Last system update**:
 - Date of the last software update, including version number
 - Status: Software for update downloaded, Software update in progress, Software update complete, Software update failed
 - Information on whether a new software update is available
 - Version information of the last software update for each of the following software types: **Bundle version**, **COM software version**, **PWR software version**

Displaying the change log

1. Select the **Wallbox settings, Software update** option in the navigation.
2. Select **Change log**.

The change log is displayed and contains information about all updated software components.

7.12.2 Manually updating the software

1. Select the **Wallbox settings, Software update** option in the navigation.
2. If new software is available for download, select it and confirm the download.
3. If automatic installation is not configured and a new software update has been downloaded, select it and confirm the installation.

A bar shows the progress of the current software update.

7.12.3 Performing an automatic software update

Automatic software updates is the default setting for the Wallbox.

Prerequisite

The automatic software update is only possible if the charging cable is unplugged.

Installation of a software update is displayed as follows:

- A bar shows the progress of current software updates on the **Software update** screen in the web app.
- On the front panel of the Wallbox the operating / error condition LED pulses white, see [Displays and controls](#).
- A corresponding message is displayed in the **Overview** in the web app.

Restrictions on control of automatic software updates

- If there is active OCPP communication, the software update is performed exclusively via the backend server.

7.12.4 Performing a local software update

In addition to server-based software updates, a local software update is also possible using the web app.

1. Select the **Wallbox settings, Software update** option in the navigation.
2. Select **Local update**. A file selection dialogue box is opened.
3. Select the image in the local network and confirm.

8 Service and cleaning

8.1 Performing recurring checks

⚠ WARNING

Risk of injury due to inadequately qualified personnel.

This can cause serious injuries and damage to equipment.

- Only trained and appropriately qualified personnel are to work on the Wallbox.

ⓘ Note



Some of the recurring checks may only be performed by a qualified electrical engineer, see table.

ⓘ Note

The operator is responsible for performing the recurring checks.

For detailed information about the required qualifications, see assembly and installation instructions.

The following recurring checks are legally stipulated:

Component	Type of check	Interval	To be performed by
Wallbox	<ul style="list-style-type: none"> ▪ Perform a visual inspection for defects. 	Daily / For every charging cycle	User/operator
Wallbox	<ul style="list-style-type: none"> ▪ Check readiness for operation. 	Daily / For every charging cycle	User/operator
Charging cable, Wallbox	<ul style="list-style-type: none"> ▪ Repeat measurements and checks in accordance with the local regulations, (e.g. DIN VDE 0701/702 in Germany). 	Annually	Qualified electrical engineer

Component	Type of check	Interval	To be performed by
Wallbox	<ul style="list-style-type: none"> Repeat measurements and checks in accordance with the local regulations, (e.g. DIN VDE 0105-100 in Germany) 	Annually	Qualified electrical engineer
Energy meter (only for version according to German calibration law)	<ul style="list-style-type: none"> Check as required by German official calibration law 	Every 8 years from date of manufacture	

Check at initial startup

ⓘ Note



At initial startup, a qualified electrical engineer must check correct installation and electrical safety of the Wallbox (e.g. in accordance with DIN VDE 0100 in Germany).

Preparing for checks under German official calibration law

ⓘ Note

This information is only relevant for the Wallbox version according to German calibration law.

- Cleaning the Wallbox for official calibration.
- Contact and make arrangements with a provider of checks under official calibration law in good time before the official calibration expires.

8.2 Wallbox Cleaning

DANGER

Risk of death due to electric shock or fire

Water in the Wallbox can lead to life-threatening injuries due to electric shock and fire.

- Never immerse the Wallbox or type 2 vehicle coupling in water.
- Do not direct any water jets, e.g. from a garden hose or high-pressure cleaner, at the Wallbox.
- Do not place any items filled with liquid on top of the Wallbox.
- Only clean the Wallbox with a dry or slightly moistened cloth.

ATTENTION

Damage to equipment due to aggressive cleaning agents

Aggressive cleaning agents (e.g. white spirit, acetone, ethanol) can damage the surface of the housing.

- Use mild cleaning agents (e.g. washing-up liquid, neutral cleaner).
- Regularly check the Wallbox for damage to the housing and for soiling.
- If necessary, clean the outside of the Wallbox with a soft dry or slightly moistened cloth.

9 Troubleshooting

9.1 Performing a self-test

The Wallbox performs an automatic self-test of its components each time it is started. In addition, the internal residual direct current detecting device (RDC-DD) is tested before every charging cycle.

If an error has been detected in the self-test, it is entered in the error list, see [Error categories](#).

9.2 Identifying and fixing errors

There are two ways to determine that there is an error:

- Directly on the Wallbox via the operating / error condition LED (4) (see [Front panel](#)).
- Via the error list in the web app

Error categories

The following error categories are displayed on the Wallbox via the operating / error condition LED (4), see (see [Front panel](#)).

Error category	Colour	Repair priority
Fatal	Red	1
Critical	Yellow	2
Non-critical	Blue	3
No error	White	-

If there is at least one error, the operating / error condition LED lights up in the colour corresponding to the error category.

If there are multiple errors, the operating / error condition LED lights up in the colour assigned to the highest error category.

ⓘ Note

If all LEDs on the front panel are lit in red, the LED control on the Wallbox has failed and there is a fatal error independently of this.

The required actions to fix the error can then be seen using the web app.

Error list

- To display the error list, select **Wallbox settings, Error list** in the web app navigation.
The error list provides the following information for each error:
 - **Cause of error**
 - **Corrective actions**
 - **Additional information:** such as status, category, time (date and time) at which the error occurred.

Alternatively, the error information can also be found under error codes, [Error codes](#).

 Note
There may be multiple entries in the error list that have the same cause (error cascade).

Error status

The following error statuses are defined:

Error status	Meaning
Active	The error is active and the cause of the error has not yet been fixed.
Passive	The cause of the error has been fixed or the error is no longer present.

9.2.1 Fixing errors

ATTENTION
Damage to equipment when fixing errors
If an error is not fixed despite correctly following the instructions for fixing errors, the Wallbox is defective.

- Do not use the Wallbox.
- Notify technical service.

1. To fix an error, select **Wallbox settings, Error list** in the web app navigation.
The error list is displayed, see [Identifying and fixing errors](#).
2. Select an error in the list.

For detailed information about the selected error, see [Error codes](#).

3. Read the detailed description carefully and then analyse and fix the error by following the instructions in the error list.

ⓘ Note on fatal errors

To fix errors in this category, the Wallbox generally has to be restarted.

If the errors can be fixed while operation is in progress, these errors are still displayed as **Active** after the cause has been fixed until the next time the Wallbox is restarted.

ⓘ Note on critical and non-critical errors

Once the cause of the error has been fixed, the status of the error immediately changes to **Passive**.

4. If multiple errors are displayed, fix the errors in order of priority, starting with fatal errors, followed by critical errors and so on.

Clearing the error list

1. As soon as the error list only contains passive errors, in the **Error list** screen in the web app select the **Delete passive errors** option.
2. Restart the Wallbox:
 - Press and hold the button on the front panel for at least 8 seconds.
 - Alternatively: Disconnect and reconnect the power supply to the Wallbox.

After switching on again, the operating / error condition LED should be white and the error list should be empty.

3. If the operating / error condition LED is not white and the error list is not yet empty, continue fixing errors.

9.2.2 Error codes

Error code	Category	Type of error	Measures to fix error
0x100000	Fatal	Self-test error on the power board	Press the button on the front panel for at least 8 seconds to restart the Wallbox. If the error is still displayed after repeated restarts, contact Support.

Error code	Category	Type of error	Measures to fix error
0x100002	Fatal	Internal communication error between power controller and board components.	Press the button on the front panel for at least 8 seconds to restart the Wallbox. If the error is still displayed after repeated restarts, contact Support.
0x100003	Fatal	Power controller power supply self-test error	Press the button on the front panel for at least 8 seconds to restart the Wallbox. If the error is still displayed after repeated restarts, contact Support.
0x100004	Fatal	Power board peripheral power supply self-test error	Press the button on the front panel for at least 8 seconds to restart the Wallbox. If the error is still displayed after repeated restarts, contact Support.
0x10000E	Fatal	Power controller has failed	Press the button on the front panel for at least 8 seconds to restart the Wallbox. If the error is still displayed after repeated restarts, contact Support.
0x10000F	Fatal	Comm controller has failed	Press the button on the front panel for at least 8 seconds to restart the Wallbox. If the error is still displayed after repeated restarts, contact Support.
0x100010	Fatal	Internal software error in power controller	Press the button on the front panel for at least 8 seconds to restart the Wallbox. If the error is still displayed after repeated restarts, contact Support.
0x100020	Fatal	Internal software error in comm controller	Press the button on the front panel for at least 8 seconds to restart the Wallbox. If the error is still displayed after repeated restarts, contact Support.

Error code	Category	Type of error	Measures to fix error
0x100023	Fatal	Internal communication error on the comm board	Press the button on the front panel for at least 8 seconds to restart the Wallbox. If the error is still displayed after repeated restarts, contact Support.
0x100025	Non-critical	Temperature compensation for LEDs failed.	Press the button on the front panel for at least 8 seconds to restart the Wallbox. Continued operation of the Wallbox is possible but the colours of the LEDs may not match those described in these instructions. If necessary, use the web app to identify the correct system status.
0x100026	Fatal	EEPROM memory on comm board faulty	Press the button on the front panel for at least 8 seconds to restart the Wallbox. If the error is still displayed after repeated restarts, contact Support.
0x100027	Fatal	Comm controller RAM memory faulty	Press the button on the front panel for at least 8 seconds to restart the Wallbox. If the error is still displayed after repeated restarts, contact Support.
0x100028	Fatal	eMMC memory on comm board faulty	Press the button on the front panel for at least 8 seconds to restart the Wallbox. If the error is still displayed after repeated restarts, contact Support.
0x100100	Fatal	Incorrect reference value for the residual direct current detecting device (RCD-DD)	Press the button on the front panel for at least 8 seconds to restart the Wallbox. If the error is still displayed after repeated restarts, contact Support.

Error code	Category	Type of error	Measures to fix error
0x100101	Fatal	Fault current (DC) detected	<p>During charging, fault currents can occur. The Wallbox detects these and then switches off as a precaution. This can be caused by unwanted side-effects of the domestic installation.</p> <ol style="list-style-type: none"> 1. Check the domestic installation of the Wallbox, if necessary with the assistance of a qualified electrical engineer. 2. Disconnect from the vehicle or press the button on the front panel for at least 8 seconds to restart the Wallbox.
0x100102	Fatal	Internal error in sensor of residual direct current detecting device (RCD-DD)	<p>Press the button on the front panel for at least 8 seconds to restart the Wallbox. If the error is still displayed after repeated restarts, contact Support.</p>
0x100103	Fatal	Self-test of the residual direct current detecting device failed (RCD-DD)	<p>Press the button on the front panel for at least 8 seconds to restart the Wallbox. If the error is still displayed after repeated restarts, contact Support.</p>
0x100104	Fatal	Earth monitoring system indicating errors.	<p>Check the domestic installation to ensure the Wallbox is correctly earthed, if necessary with the assistance of a qualified electrical engineer. If the error is still displayed after checking the installation, contact Support.</p> <p>If earth monitoring is not possible in your country for technical reasons, or does not work reliably, disable it, see Enabling/disabling the earth monitoring system.</p>

Error code	Category	Type of error	Measures to fix error
0x100106	Fatal	Implausible load relay 1 status	Press the button on the front panel for at least 8 seconds to restart the Wallbox. If the error is still displayed after repeated restarts, contact Support.
0x100107	Fatal	Implausible load relay 2 status	Press the button on the front panel for at least 8 seconds to restart the Wallbox. If the error is still displayed after repeated restarts, contact Support.
0x10010D	Non-critical	Earth monitoring system disabled	Earth monitoring system has been disabled using web app. If earth monitoring system is to be enabled, see Enabling/disabling the earth monitoring system .
0x100110	Fatal	Load relay continuously tripped	Press the button on the front panel for at least 8 seconds to restart the Wallbox. If the error is still displayed after repeated restarts, contact Support.
0x100120	Fatal	Vehicle connector lock on socket faulty	Press the button on the front panel for at least 8 seconds to restart the Wallbox. If the error is still displayed after repeated restarts, contact Support.
0x100121	Fatal	Vehicle connector socket self-test failed	Press the button on the front panel for at least 8 seconds to restart the Wallbox. If the error is still displayed after repeated restarts, contact Support.
0x200200	Critical	Implausible voltage on control line to vehicle	Check that the on-board charger on your electric vehicle is functioning correctly. If you have connected your own charging cable to the socket, check it and if necessary use a different charging cable.

Error code	Category	Type of error	Measures to fix error
0x200201	Critical	Vehicle requesting ventilation.	The electric vehicle is requesting ventilation. As this is not supported by the Wallbox, the Wallbox cannot be used for charging this vehicle.
0x300000	Non-critical	WiFi module self-test failed	Press the button on the front panel for at least 8 seconds to restart the Wallbox. If the error is still displayed after repeated restarts, use the Ethernet or LTE connection as an alternative.
0x300001	Non-critical	WiFi connection error	Check whether the WiFi signal strength is sufficient for a connection and that the access data (SSID, password) has been entered correctly. If necessary, restart the WiFi access point in your network and confirm any security prompts.
0x300003	Non-critical	PLC module self-test failed	Press the button on the front panel for at least 8 seconds to restart the Wallbox. If the error is still displayed after repeated restarts, the Wallbox is unable to carry out charging using Plug & Charge. Instead, only charging without advanced communication is possible.
0x300005	Non-critical	PLC connection to vehicle communication error	Check that the on-board charger on your electric vehicle is functioning correctly. If you have connected your own charging cable to the socket, check it and if necessary use a different charging cable. If the error persists, only charging without advanced communication is possible.

Error code	Category	Type of error	Measures to fix error
0x300006	Fatal	Invalid combination of hardware version and software	Use the software update function to install a compatible software package on the Wallbox, see Manually updating the software . If the error is still displayed after a successful software update, contact Support and have the installation checked by a qualified electrical engineer.
0x30000F	Fatal	Invalid combination of hardware version and software	Use the software update function to install a compatible software package on the Wallbox, see Manually updating the software . If the error is still displayed after a successful software update, contact Support.
0x300100	Non-critical	Ethernet module self-test failed	Press the button on the front panel for at least 8 seconds to restart the Wallbox. If the error is still displayed after repeated restarts, use the Ethernet or LTE connection as an alternative.
0x300101	Non-critical	Ethernet connection error	Check the cable, switch, network configuration and security settings on the connected computer. The Wallbox is not suitable for direct connection to another computer (ad-hoc connection). A connection via WiFi or LTE is possible as an alternative.
0x300200	Non-critical	LTE module self-test failed	Press the button on the front panel for at least 8 seconds to restart the Wallbox. If the error is still displayed after repeated restarts, use the WiFi or Ethernet connection as an alternative.

Error code	Category	Type of error	Measures to fix error
0x300201	Non-critical	LTE connection or authorisation error	Check, using a smartphone for example, whether the LTE reception in the area around the Wallbox is guaranteed to have sufficient signal strength for your provider. Check that access data has been entered correctly. Alternatively, use the WiFi or Ethernet connection.
0x300202	Non-critical	LTE signal strength too low	Wait until there is a signal level with sufficient strength or if necessary switch to Ethernet or WiFi. Observe the information in the assembly and installation instructions for selecting the location for your Wallbox. If reception conditions are difficult, use an LTE repeater if necessary.
0x300300	Non-critical	RFID module faulty	Press the button on the front panel for at least 8 seconds to restart the Wallbox. If the error is still displayed after repeated restarts, charging approval is only possible using one of the other authorisation options or by switching off authorisation.
0x300301	Non-critical	RFID chip invalid or cannot be read	Register an RFID chip for the Wallbox before it can be used for charging approval, see Adding an RFID chip to the approved list . Check that you are using a functioning RFID chip that meets the supported standards set out in these instructions. Hold the RFID chip sufficiently close to the marked sensor and wait for the acoustic and visual response from the Wallbox before removing the RFID chip from the sensor.

Error code	Category	Type of error	Measures to fix error
0x300400	Fatal	Malfunction in energy meter	Check whether the official calibration interval for the energy meter has elapsed and contact your CPO for assistance. If the official calibration interval has not yet elapsed, press the button on the front panel for at least 8 seconds to restart the Wallbox. If the error is still displayed after a successful software update, contact Support.
0x300401	Fatal	Connection to energy meter interrupted	Press the button on the front panel for at least 8 seconds to restart the Wallbox. If the error is still displayed after repeated restarts, you must have the installation of the energy meter checked by a qualified electrical engineer or contact Support.
0x40100C	Non-critical	Attempt to establish vehicle communication via HLC failed	The Wallbox could not establish communication with the vehicle via ISO 15118 (HLC). Check whether the vehicle supports and has enabled this advanced communication. Check the charging cable. Alternatively, charging without advanced communication is possible. Disable the PLC connection, see Configuring the PLC connection to the vehicle .

Error code	Category	Type of error	Measures to fix error
0x40100E	Non-critical	Vehicle error (Matching error)	<p>The Wallbox recognised an ISO 15118-capable vehicle and established a connection, but was unable to start the protocol. Check the configuration on the vehicle – this error mainly occurs if the vehicle is set to charge with direct current (DC). Alternatively, charging without advanced communication is possible.</p> <p>Disable the PLC connection, see Configuring the PLC connection to the vehicle.</p>
0x40100F	Non-critical	Vehicle error (Sequence error)	<p>The Wallbox recognised an ISO 15118-capable vehicle and established a connection, but was unable to start the protocol. Check the configuration on the vehicle – this error mainly occurs if the vehicle is set to charge with direct current (DC). Alternatively, charging without advanced communication is possible.</p> <p>Disable the PLC connection, see Configuring the PLC connection to the vehicle.</p>
0x401011	Non-critical	Vehicle error (Invalid session ID)	<p>The Wallbox recognised an ISO 15118-capable vehicle and established a connection, but detected an incompatibility with the protocol used. Check the configuration on the vehicle. Alternatively, charging without advanced communication is possible.</p> <p>Disable the PLC connection, see Configuring the PLC connection to the vehicle.</p>

Error code	Category	Type of error	Measures to fix error
0x401012	Non-critical	Vehicle error (Invalid service ID)	The Wallbox recognised an ISO 15118-capable vehicle and established a connection, but detected an incompatibility with the protocol used. Check the configuration on the vehicle. Alternatively, charging without advanced communication is possible. Disable the PLC connection, see Configuring the PLC connection to the vehicle .
0x401013	Non-critical	Vehicle error (Invalid payment method)	The Wallbox recognised an ISO 15118-capable vehicle and established a connection, but was unable to detect a suitable payment method. If you want to use the vehicle for PnC (Plug & Charge), check whether a suitable certificate is installed on the vehicle. Alternatively, charging without advanced communication is possible. Disable the PLC connection, see Configuring the PLC connection to the vehicle .
0x401014	Non-critical	Vehicle error (Service selection)	The Wallbox recognised an ISO 15118-capable vehicle and established a connection, but detected an incompatibility with the protocol used. Check the configuration on the vehicle. Alternatively, charging without advanced communication is possible. Disable the PLC connection, see Configuring the PLC connection to the vehicle .

Error code	Category	Type of error	Measures to fix error
0x401015	Non-critical	Plug & Charge (PnC): Certificate expired	The Wallbox recognised a PnC-capable vehicle and established a connection, but detected an invalid certificate. Install a valid certificate either locally or after contacting the CPO. Alternatively, charging without advanced communication is possible, (disable the PLC connection, see Configuring the PLC connection to the vehicle), or auto charge is possible.
0x401016	Non-critical	Plug & Charge (PnC): Certificate revoked	The Wallbox recognised a PnC-capable vehicle and established a connection, but a certificate that is no longer valid was detected. Install a valid certificate either locally or after contacting the CPO. Alternatively, charging without advanced communication or auto charge is possible.
0x401017	Non-critical	Plug & Charge (PnC): No certificate available	The Wallbox recognised a PnC-capable vehicle and established a connection, but did not recognise a certificate. Install a certificate either locally or after contacting the CPO. Alternatively, charging without advanced communication or auto charge is possible.
0x401018	Non-critical	Plug & Charge (PnC): Error processing certificate	The Wallbox recognised a PnC-capable vehicle and established a connection, but was unable to process the certificate. Install a new certificate either locally or after contacting the CPO. Alternatively, charging without advanced communication or auto charge is possible.

Error code	Category	Type of error	Measures to fix error
0x401019	Non-critical	Plug & Charge (PnC): Certificate invalid	The Wallbox recognised a PnC-capable vehicle and established a connection, but detected an invalid certificate. Install a valid certificate either locally or after contacting the CPO. Alternatively, charging without advanced communication or auto charge is possible.
0x40101A	Non-critical	Plug & Charge (PnC): Error processing certificate (Challenge invalid)	The Wallbox recognised a PnC-capable vehicle and established a connection, but was unable to process the certificate. Install a new certificate either locally or after contacting the CPO. Alternatively, charging without advanced communication or auto charge is possible.
0x40101B	Non-critical	Vehicle error (incorrect energy transfer mode)	The Wallbox recognised an ISO 15118-capable vehicle and established a connection, but detected an incompatibility with the protocol used. Check the configuration on the vehicle. Alternatively, charging without advanced communication is possible.
0x40101C	Non-critical	Vehicle error (incorrect charging parameters)	The Wallbox recognised an ISO 15118-capable vehicle and established a connection, but detected an incompatibility with the protocol used. Check the configuration on the vehicle. Alternatively, charging without advanced communication is possible.

Error code	Category	Type of error	Measures to fix error
0x40101D	Non-critical	Vehicle error (Charging profile invalid)	The Wallbox recognised an ISO 15118-capable vehicle and established a connection, but detected an incompatibility with the protocol used. Check the configuration on the vehicle. Alternatively, charging without advanced communication is possible.
0x40101E	Non-critical	Vehicle error (Invalid tariff selection)	The Wallbox recognised an ISO 15118-capable vehicle and established a connection, but detected an incompatibility with the protocol used. Check the configuration on the vehicle. Alternatively, charging without advanced communication is possible.
0x401020	Non-critical	Vehicle error (No charging service selected)	The Wallbox recognised an ISO 15118-capable vehicle and established a connection, but detected an incompatibility with the protocol used. Check the configuration on the vehicle. Alternatively, charging without advanced communication is possible.
0x401025	Non-critical	Error establishing the connection to the vehicle over TCP	The Wallbox recognised an ISO 15118-compatible vehicle, but could not establish a connection. Check the configuration on the vehicle or repeat PnC by briefly interrupting and restoring the vehicle connection. Alternatively, charging without advanced communication is possible.

Error code	Category	Type of error	Measures to fix error
0x401026	Non-critical	Vehicle error (Connection to the vehicle via HLC cancelled)	An existing connection to the vehicle via HLC has timed out, and the Wallbox has switched to charging without advanced communication. Briefly interrupt the vehicle connection and re-establish the connection. Alternatively, charging without advanced communication is possible.
0x401027	Non-critical	Connection to energy management system (EMS) cancelled	Check whether the EMS is switched on and connected to your network. Either an Ethernet or WiFi connection is required; a connection via LTE is not possible. If necessary, check the security setting in your network.
0x401028	Non-critical	Energy management system: Service for blackout protection is not available.	Check the configuration of your energy management system.
0x401029	Non-critical	Energy management system: Service for domestic current charging is not available.	Check the configuration of your energy management system and your photovoltaic system.
0x40102A	Non-critical	Energy management system: Service for cost-optimised charging is not available.	Check the configuration of your energy management system in terms of the tariff settings.

Error code	Category	Type of error	Measures to fix error
0x401100	Fatal	Error in the phase switching sequence.	An unexpected error has occurred during phase switching from 3-phase to 1-phase operation or vice versa. Press the button on the front panel for at least 8 seconds to restart the Wallbox. Phase switching must then be triggered again.
0x401101	Fatal	Error in the phase switching configuration.	The Wallbox supports phase switching for 3-phase and 1-phase operation, but is not configured correctly. Check whether the DIP switch setting indicates 3-phase operation or whether 3-phase operation has been set via the web app. If the error still occurs after restarting, contact Support.
0x402000	Critical	OCPP configuration incorrect	Check and correct the OCPP configuration and contact the CPO if the problem persists.
0x402001	Critical	Certificate for login via OCPP missing or is invalid.	Contact the CPO of the OCPP backend.
0x402002	Non-critical	Connection to OCPP server cancelled	Check the server connection. Any active charging is continued.
0x402003	Critical	Wallbox not authorised for OCPP	Contact the CPO.
0x402004	Non-critical	Charging authorisation via OCPP failed	Check that you have used the correct authorisation method (RFID chip) and/or that the vehicle used is approved for the Wallbox.
0x402005	Non-critical	Unsupported query from OCPP server	If necessary, notify the CPO. Active charging is continued.

Error code	Category	Type of error	Measures to fix error
0x402006	Non-critical	Unknown data from OCPP server	If necessary, notify the CPO. Active charging is continued.
0x500000	Non-critical	Light sensor failed	Press the button on the front panel for at least 8 seconds to restart the Wallbox. If the error is still displayed after the restart, operation of the device can continue anyway. The light intensity of the LEDs may not be adjusted to the brightness of the surroundings. If required, set the required brightness manually, see Setting the LED brightness .
0x500001	Fatal	Activation of LEDs faulty	Press the button on the front panel for at least 8 seconds to restart the Wallbox. If the error is still displayed after repeated restarts, contact Support (no longer reliable indication using LEDs).
0x500002	Non-critical	Button malfunction	Restart the Wallbox by temporarily connecting from the mains supply. If the error is still displayed after repeated restarts, check the installation or contact Support (restart or activation from eco mode then no longer function).
0xC00201	Critical	Internal communication error between power board and comm board	Press the button on the front panel for at least 8 seconds to restart the Wallbox. If the error is still displayed after repeated restarts, contact Support.
0xC00304	Fatal	Incompatible power controller and comm controller software version	If necessary, repeat the last software update performed, see Manually updating the software . If the error is still displayed after a successful software update, contact Support.

Error code	Category	Type of error	Measures to fix error
0xD1210A	Critical	Internal communication error on the comm controller	Press the button on the front panel for at least 8 seconds to restart the Wallbox. If the error is still displayed after repeated restarts, contact Support.
0xD20001	Critical	Internal communication error between power board and comm board	Press the button on the front panel for at least 8 seconds to restart the Wallbox. If the error is still displayed after repeated restarts, contact Support.
0xD20002	Critical	Internal communication error between power board and comm board when starting	Press the button on the front panel for at least 8 seconds to restart the Wallbox. If the error is still displayed after repeated restarts, contact Support.
0xE10202	Critical	Overvoltage on phase L1	Have the installation checked by a qualified electrical engineer. In particular, the mains connection has to be checked and if necessary repaired (high voltage resistance measurement, visual inspection for kinks, crushing, etc.). If the installation is not faulty, contact Support.
0xE10203	Critical	Undervoltage on phase L1	Have the installation checked by a qualified electrical engineer. In particular, the mains connection has to be checked and if necessary repaired (high voltage resistance measurement, visual inspection for kinks, crushing, etc.). If the installation is not faulty, contact Support.

Error code	Category	Type of error	Measures to fix error
0xE10212	Critical	Overvoltage on phase L2	Have the installation checked by a qualified electrical engineer. In particular, the mains connection has to be checked and if necessary repaired (high voltage resistance measurement, visual inspection for kinks, crushing, etc.). If the installation is not faulty, contact Support.
0xE10213	Non-critical	Undervoltage on phase L2	Have the installation checked by a qualified electrical engineer. In particular, the mains connection has to be checked and if necessary repaired (high voltage resistance measurement, visual inspection for kinks, crushing, etc.). If the installation is not faulty, contact Support.
0xE10222	Critical	Overvoltage on phase L3	Have the installation checked by a qualified electrical engineer. In particular, the mains connection has to be checked and if necessary repaired (high voltage resistance measurement, visual inspection for kinks, crushing, etc.). If the installation is not faulty, contact Support.
0xE10223	Non-critical	Undervoltage on phase L3	Have the installation checked by a qualified electrical engineer. In particular, the mains connection has to be checked and if necessary repaired (high voltage resistance measurement, visual inspection for kinks, crushing, etc.). If the installation is not faulty, contact Support.

Error code	Category	Type of error	Measures to fix error
0xE10231	Critical	Input current on phase L1 too high	Have the installation checked by a qualified electrical engineer. In particular, the mains connection has to be checked and if necessary repaired (high voltage resistance measurement, visual inspection for kinks, crushing, etc.). If the installation is not faulty, contact Support.
0xE10241	Critical	Input current on phase L2 too high	Have the installation checked by a qualified electrical engineer. In particular, the mains connection has to be checked and if necessary repaired (high voltage resistance measurement, visual inspection for kinks, crushing, etc.). If the installation is not faulty, contact Support.
0xE10251	Critical	Input current on phase L3 too high	Have the installation checked by a qualified electrical engineer. In particular, the mains connection has to be checked and if necessary repaired (high voltage resistance measurement, visual inspection for kinks, crushing, etc.). If the installation is not faulty, contact Support.
0xE102A0	Fatal	Error in power board peripherals	Press the button on the front panel for at least 8 seconds to restart the Wallbox. If the error is still displayed after repeated restarts, contact Support.

Error code	Category	Type of error	Measures to fix error
0xE10300	Critical	Mains frequency outside the permitted range	<p>If there is a mains fault at the domestic connection, the Wallbox cannot be operated until the fault has been fixed.</p> <p>Have the installation checked by a qualified electrical engineer. In particular, the mains connection has to be checked and if necessary repaired (high voltage resistance measurement, visual inspection for kinks, crushing, etc.). If the installation is not faulty, contact Support.</p>
0xFF000D	Fatal	Invalid encoding value for charging cable current-carrying capacity	<p>The charging cable is faulty or cannot be operated with this Wallbox. If you are using your own charging cable, try using a different charging cable. If the charging cable is permanently connected to the Wallbox, press the button on the front panel for at least 8 seconds to restart the Wallbox. If the error is still displayed after repeated restarts, contact Support.</p>
0xFF000E	Fatal	Infrastructure configuration error (DIP switch / rotary switch)	<p>The installation settings for the DIP switch and/or rotary switch are not correct or have not been correctly detected. Have the installation checked by a qualified electrical engineer. If the error is still displayed after restarting and correcting the settings, contact Support.</p>
0xFF0101	Critical	No charging possible due to low temperature (Sensor on power controller)	<p>Wait until the Wallbox has heated back up to an appropriate operating temperature. For indoor installation, check the air conditioning system / heating settings.</p>

Error code	Category	Type of error	Measures to fix error
0xFF0102	Non-critical	Charging current reduction due to high temperature (Sensor on power controller)	Allow for a longer charging time. For indoor installation, check the air conditioning system / room cooling settings.
0xFF0103	Fatal	Temperature sensor on power controller outside valid range	Press the button on the front panel for at least 8 seconds to restart the Wallbox. If the error is still displayed after repeated restarts, contact Support (charging no longer possible).
0xFF0104	Critical	No charging possible due to critical temperature (sensor on power controller)	Wait until the Wallbox has cooled back down to the permitted operating temperature. For indoor installation, check the air conditioning system / room cooling settings.
0xFF0201	Critical	No charging possible due to low temperature (Sensor on relay)	Wait until the Wallbox has heated back up to an appropriate operating temperature. For indoor installation, check the air conditioning system / heating settings.
0xFF0202	Non-critical	Charging current reduction due to high temperature (sensor on relay)	Allow for a longer charging time. For indoor installation, check the air conditioning system / room cooling settings.
0xFF0203	Fatal	Temperature sensor on relay outside valid range	Press the button on the front panel for at least 8 seconds to restart the Wallbox. If the error is still displayed after repeated restarts, contact Support (charging no longer possible).

Error code	Category	Type of error	Measures to fix error
0xFF0204	Critical	No charging possible due to critical temperature (sensor on relay)	Wait until the Wallbox has cooled back down to the permitted operating temperature. For indoor installation, check the air conditioning system / room cooling settings.
0xFF0301	Critical	No charging possible due to low temperature (Sensor in input path or at output of load relay 1)	Wait until the Wallbox has heated back up to an appropriate operating temperature. For indoor installation, check the air conditioning system / heating settings.
0xFF0302	Non-critical	Charging current reduction due to high temperature (Sensor in input path or at output of load relay 1)	Allow for a longer charging time. For indoor installation, check the air conditioning system / room cooling settings.
0xFF0303	Fatal	Temperature sensor in input path or at output of load relay 1 outside valid range	Press the button on the front panel for at least 8 seconds to restart the Wallbox. If the error is still displayed after repeated restarts, contact Support (charging no longer possible).
0xFF0304	Critical	No charging possible due to critical temperature (sensor in input path or at output of load relay 1)	Wait until the Wallbox has cooled back down to the permitted operating temperature. For indoor installation, check the air conditioning system / room cooling settings.

Error code	Category	Type of error	Measures to fix error
0xFF0401	Critical	No charging possible due to low temperature (sensor in output path or at output of load relay 2)	Wait until the Wallbox has heated back up to an appropriate operating temperature. For indoor installation, check the air conditioning system / heating settings.
0xFF0402	Non-critical	Charging current reduction due to high temperature (sensor in output path or at output of load relay 2)	Allow for a longer charging time. For indoor installation, check the air conditioning system / room cooling settings.
0xFF0403	Fatal	Temperature sensor in output path or at output of load relay 2 outside valid range	Press the button on the front panel for at least 8 seconds to restart the Wallbox. If the error is still displayed after repeated restarts, contact Support (charging no longer possible).
0xFF0404	Critical	No charging possible due to critical temperature (sensor in output path or at output of load relay 2)	Wait until the Wallbox has cooled back down to the permitted operating temperature. For indoor installation, check the air conditioning system / room cooling settings.
0xFF0501	Critical	No charging possible due to low temperature (Sensor on socket)	Wait until the Wallbox has heated back up to an appropriate operating temperature. For indoor installation, check the air conditioning system / heating settings.

Error code	Category	Type of error	Measures to fix error
0xFF0502	Non-critical	Charging current reduction due to high temperature (Sensor on socket)	Allow for a longer charging time. For indoor installation, check the air conditioning system / room cooling settings.
0xFF0503	Fatal	Temperature sensor on socket outside valid range	Press the button on the front panel for at least 8 seconds to restart the Wallbox. If the error is still displayed after repeated restarts, contact Support (charging no longer possible).
0xFF0504	Critical	No charging possible due to critical temperature (sensor on socket)	Wait until the Wallbox has cooled back down to the permitted operating temperature. For indoor installation, check the air conditioning system / room cooling settings.
0xFF0902	Non-critical	Charging current reduction due to high temperature (Sensor on comm controller)	Allow for a longer charging time. For indoor installation, check the air conditioning system / room cooling settings.
0xFF0903	Non-critical	Temperature sensor on comm controller outside valid range	Press the button on the front panel for at least 8 seconds to restart the Wallbox. If the error is still displayed after repeated restarts, contact Support.

9.3 Initiating emergency measures

 **DANGER**

Risk of death due to electric shock

Contact with live parts results in a direct risk of death due to electric shock.

- In case of emergency or when fixing errors or carrying out electrical work on the Wallbox, comply with the following **Safety rules**:
 - Disconnect.
 - Secure against being switched on again.
 - Ensure that there is no voltage.
 - Earth and short-circuit.
 - Cover any adjacent live parts and secure the danger area.

In an emergency, if the Wallbox or parts of the Wallbox catch fire, suffer water damage or are destroyed due to vandalism:

1. Follow all five safety rules listed in the warning notice to ensure that the voltage is disconnected.
2. Contact support, see rear of these instructions.

10 Shutdown and uninstalling

① Further information

For detailed information about shutting down and uninstalling the Wallbox, refer to the Shutdown and uninstalling instructions.

ATTENTION

Sensitive data on the Wallbox

You can use the web app to enter custom texts and load images to the Wallbox.

- Always reset the Wallbox to the factory defaults before resale or shipping for repair.

11 Storage

- Clean the Wallbox before storage, see [Wallbox Cleaning](#).
- Store the Wallbox in the original packaging or other suitable packaging in a clean and dry location.
- Observe the permissible storage temperature.

For detailed information about the permissible storage temperature and other environmental specifications, see [Technical data](#).

12 Disposal



The Wallbox is subject to the EU Directive 2012/19/EU on waste electrical and electronic equipment.

Disposal of the wallbox

Prerequisite



Before disposal, a qualified electrical engineer must disconnect the Wallbox from the power supply and shut it down in accordance with the regulations, see assembly and installation instructions, "Shutdown and uninstalling".

1. At the end of its service life, dispose of the Wallbox in line with the national statutory regulations for electrical and electronic equipment, as well as any local disposal regulations.
2. Dispose of waste equipment through your specialist dealer or a collection point for waste equipment, not with domestic or bulky waste.
3. Dispose of the packaging material using the standard local collection facilities for cardboard, paper and plastics. Observe local disposal regulations.

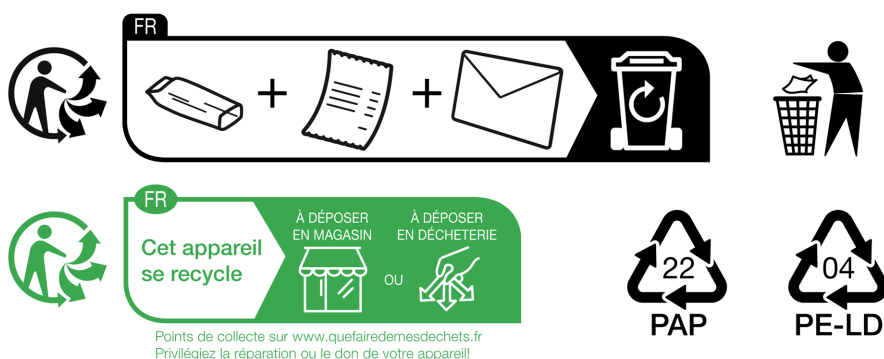

Raccolta Carta

Verifica le disposizioni del tuo Comune

Raccolta Plastica

Verifica le disposizioni del tuo Comune

Paper Collection

Check the provisions of your municipality

13 Technical data

Electrical data

Wallbox version	GHO11E10K/ GHO11E100K/ GHO11E102K	GHO22E10K/ GHO22E100K/ GHO22E102K	GHO11E21K/ GHO11E210K/ GHO11E212K	GHO22E21K/ GHO22E210K/ GHO22E212K	GHO22E22K/ GHO22E221K/ GHO22E223K	
	Power [kW]	11	22	11	22	22
	Mains voltage [V]	220 - 240 / 380 - 415			230 / 400	
Mains frequency [Hz]	50 / 60					
Rated current [A]	16	32	16	32	32	
Charging capacity, Mode 3 [kW]	11	22	11	22	22	
Charging current, Mode 3 [A]	3 x 16	3 x 32	3 x 16	3 x 32	3 x 32	
Mains connection	L1, L2, L3, N, PE					
Overvoltage category (IEC 60664)	III					
Residual direct current detecting device (RDC-DD) [mA DC]	IΔN 6					
Vehicle coupling	Type 2					
Rated impulse voltage U_{imp} [kV]	4					
Rated insulation voltage [V]	500					

Wallbox version	GHO11E10K/ GHO11E100K/ GHO11E102K	GHO22E10K/ GHO22E100K/ GHO22E102K	GHO11E21K/ GHO11E210K/ GHO11E212K	GHO22E21K/ GHO22E210K/ GHO22E212K	GHO22E22K/ GHO22E221K/ GHO22E223K
Rated current of switchgear combination [A]	16	32	16	32	32
Rated conditional short-circuit current I _{cc} [kA]			3		
Rated load factor RDF			1		
Mains type	TT/TN 3 and 1-phase; IT 1-phase				
Protection class	I				
EMC classification	A/B				
Energy consumption [W]					
• With eco mode	<1				
• Without eco mode	< 7 (vehicle not connected)		< 8 (vehicle not connected)		

Mechanical data

Wallbox version	GHO11E10K/ GHO11E100K/ GHO11E102K	GHO22E10K/ GHO22E100K/ GHO22E102K	GHO11E21K/ GHO11E210K/ GHO11E212K	GHO22E21K/ GHO22E210K/ GHO22E212K	GHO22E22K/ GHO22E221K/ GHO22E223K
Dimensions (H x W x D) [mm]	384 x 384 x 181	384 x 384 x 181	384 x 384 x 181	384 x 384 x 181	384 x 384 x 202
Weight (excluding cable) [kg]	3.15		3.57		3.99
Weight (cable) [kg]	1.5 / 2.1	2.6 / 3.8	1.5 / 2.1	2.6 / 3.8	-
Charging cable length [m]	4.5 / 7	4.5 / 7	4.5 / 7	4.5 / 7	-

Connection

Wallbox version	GHO11E10K/ GHO11E100K/ GHO11E102K	GHO22E10K/ GHO22E100K/ GHO22E102K	GHO11E21K/ GHO11E210K/ GHO11E212K	GHO22E21K/ GHO22E210K/ GHO22E212K	GHO22E22K/ GHO22E221K/ GHO22E223K	
	Supply line, nominal cross-section [mm ²]	5 x 2.5/4	5 x 6/10	5 x 2.5/4	5 x 6/10	5 x 6/10
	Supply line, clamping range [mm ²]	Rigid: 0.5 - 16				
Tightening torque [Nm]	1.5 - 1.8					
Ethernet RJ45	Cat. 5/6/7					
External control cable U [V]	24 ± 20%					
External control cable, clamping range [mm ²]	Rigid: 0.2 - 4					

Ambient and storage conditions

Wallbox version	GHO11E10K/ GHO11E100K/ GHO11E102K	GHO22E10K/ GHO22E100K/ GHO22E102K	GHO11E21K/ GHO11E210K/ GHO11E212K	GHO22E21K/ GHO22E210K/ GHO22E212K	GHO22E22K/ GHO22E221K/ GHO22E223K	
	Protection rating	IP55				
	Shock resistance	IK10				
Degree of contamination	3					
Positioning	Open air or inside building					
Stationary / mobile	Stationary					
Use (in accordance with DIN EN 61439-7)	AEVCS					
Exterior design	Wall mounting					

Wallbox version	GHO11E10K/ GHO11E100K/ GHO11E102K	GHO22E10K/ GHO22E100K/ GHO22E102K	GHO11E21K/ GHO11E210K/ GHO11E212K	GHO22E21K/ GHO22E210K/ GHO22E212K	GHO22E22K/ GHO22E221K/ GHO22E223K	
	Ambient temperature [° C]	-30 to +45		-25 to +45		-25 to +45
	Storage temperature [° C]	-30 to +80				
Humidity for operation (non-condensing) [%]	5 - 95					
Maximum altitude	3,000		2,000		2,000	

Applicable standards

- IEC 61851-1
- IEC/TS 61439-7
- HD 60364-7-722
- IEC 62955¹

Additional standards for version according to German calibration law only

- Mess- und Eichgesetz (MessEG) (measurement and calibration law)
- Mess- und Eichverordnung (MessEV) (measurement and calibration ordinance)

EU conformity

eSystems MTG GmbH hereby declares that the following radio equipment types GHO11E10*, GHO11E100*, GHO11E102*, GHO22E10*, GHO22E100*, GHO22E102*, GHO11E21*, GHO11E210*, GHO11E212*, GHO22E21*, GHO22E210*, GHO22E212*, GHO22E22*, GHO22E221*, GHO22E223* comply with Directive 2014/53/EU.

*x may represent any letter.

¹The mechanical coupling required by IEC 62955 is implemented by an electrical coupling with an equivalent level of safety.



For the full text of the EU Declaration of Conformity, see <https://public.evse-manuals.com/universal/index.html>

Structure of the type name of the Wallbox

For information on whether the 1-/3-phase switching may be used with the vehicle, see the vehicle manufacturer's documentation or contact the vehicle manufacturer.

The type name can be used to determine whether 1-/3-phase switching is possible for this Wallbox version. This information can be found in the 9th character in the type name. For a better understanding, see the example: GHO 11 E 1 0 **2** K

9th character in the type name	Charging option	1-/3-phase switching
0	With charging cable	without
1	With socket	without
2	With charging cable	with
3	With socket	with

14 Technical glossary

A

AC

Alternating Current

C

CPO

Charge Point Operator Company that operates, manages and sets up a network of charging stations

D

DC

Direct Current

E

EEBUS

Communication interface for energy management in the IoT (Internet of Things)

EMSP

Electromobility service provider

H

HEMS

Home Energy Management System

HLC

High-level communication

I

ICCID

Integrated Circuit Card Identifier. Identifies the SIM card required for LTE.

IMEI

International Mobile Equipment Identity. Identifies the transmission and receiving module required for LTE.

IMSI

International Mobile Subscriber Identity. Identifies the wallbox as a subscriber in the LTE network.

IP

Internet Protocol

ISO 15118

Charging with advanced communication

L

LTE

Long Term Evolution. 4th generation mobile wireless standard

M

MODBUS/RTU

MODBUS/Remote Terminal Unit Communication between energy meter and wallbox connected via RS485

O

OCPP

Open Charge Point Protocol

OTA

Over The Air

P

PUK

Personal Unblocking Key

PV

Photovoltaics (technology for converting solar energy into electrical energy)

R

RFID

Radio Frequency Identification. Contactless identification of people and objects using radio waves

S

SELV

Safety Extra Low Voltage

SoC

State of Charge. Charge level of the battery

T

TCP

Transmission Control Protocol

W

WLAN

Wireless Local Area Network. Local wireless network

15 Index

1

1-/3-phase switching *41*

A

Access data *18*

Ambient conditions *92*

Approved list

 Add RFID chip *42*

 Edit RFID chip data *43*

 Remove RFID chip *44*

Assembly *25*

Authentication

 Wallbox *33*

B

Button *24*

C

Charging

 Finish *39*

 Information *40*

 Pause *39*

 Settings *40*

 Start *36*

 With RFID chip *38*

Check

 At initial startup *57*

 Official calibration law *57*

Checks

 Recurring *56*

Cleaning

 Wallbox *58*

Connect

 Via OCPP *44*

Connecting

 LTE *32*

 Via web app *27*

 WiFi client *31*

 WiFi hotspot *29*

Connecting the wallbox

 Ethernet *28*

Connection *92*

Controls *21*

Copyright *7*

D

Decorative panel

 Removing *25*

Design *13*

 Web app *20*

Displays *21*

Displays and controls *22*

Disposal *89*

Documentation

 Concept *6*

 Storage *7*

E

Eco mode

 Disable *47*

 Enable *47*

EEBUS device

 Connect *45*

Electrical data *90*

Emergency measures *86*

Energy consumption *91*

Energy meter

 Showing status *51*

Error categories *59*

Error codes *61*

Error list *60*

 Clearing *61*

Error status *60*

Errors

 Fixing *60*

Ethernet

 Connecting the wallbox *28*

- EU conformity 93
- F**
- Factory defaults
 - Reset 52
- Factory reset
 - Reset 52
- Finish
 - Charging 39
- Free-Charging (charging without authentication)
 - Enable 42
- Front panel 21
 - Button 24
 - Displays and controls 22
 - Overview 21
 - RFID sensor 24
- Functions 14
- H**
- HEMS
 - Configure 45
 - Connect 45
- I**
- Installation 25
- Instructions
 - Concept 6
- Intended use 6, 11
- Items supplied 17
- L**
- Lead seal
 - Attaching 25
 - Removing 26
- LED brightness
 - Setting 47
- LEDs 22
 - Setting brightness 47
- Legal notices 7
- Lock
 - Attaching 25
 - Removing 26
- Login
 - Wallbox 33
 - Web app 34
- Logout
 - Web app 34
- LTE
 - Connecting 32
- M**
- Manufacturer's seal 8
- Maximum current
 - Configuration 40
- Means of representation 8
- Mechanical data 91
- O**
- OCPP
 - Connect wallbox 44
- Official calibration conformity 8
- Official calibration law
 - Recurring check 57
- Operator's seal 8
- Overview
 - Information 35
- P**
- Password
 - Changing 47
- Pause
 - Charging 39
- PLC connection
 - Configuring 40

Product overview *13*

Q

QR code sticker *8*

R

Rating plate *16*

Recurring checks *56*

Reset

 Factory defaults *52*

 To factory defaults *52*

Restart

 Wallbox *52*

RFID chip

 Add to approved list *42*

 Charging *38*

 Remove from approved list *44*

RFID chip data

 Edit in approved list *43*

RFID sensor *24*

Roles *27*

S

Safety *10*

Safety information *11*

Safety symbols *10*

Screenshots *9*

Self-test *59*

Set units *50*

Setting the earth monitoring
 system *50*

Setting the language *48*

Shutdown *87*

Socket *24*

Socket locking

 Configuring *50*

Socket unlocking

 Configuring *50*

Software

 Automatic update *54*

 Local update *55*

 Manual update *54*

Software updates

 Information *53*

Standards *93*

Start

 Charging *36*

Storage *88*

 Documentation *7*

Storage conditions *92*

System settings

 Show *49*

T

Target group *6*

Technical data *90*

Temperature units

 Set *50*

Troubleshooting *59*

U

Uninstalling *87*

Unregistered charging

 Disable *42*

Use

 Intended *11*

 Web app *7*

User roles *27*

W

Wallbox

 Cleaning *58*

 Design *13*

 Restarting *52*

Warning notices

 Layout *10*

 Symbols *10*

Web app

 Connecting *27*

 Design *20*

 Login *34*

 Logout *34*

- WiFi client
 - Connecting 31
- WiFi connection
 - Disconnecting 32
- WiFi hotspot
 - Connecting 29

Support

Hotline: +49 7024 40 59 88 00

E-Mail: support@esystems-mtg.de

Product Security Incident Response Team

psirt@esystems-mtg.de

eSystems MTG GmbH

Bahnhofstr. 100

73240 Wendlingen

Germany

www.esystems.de